

P. **Prince**

PTO PUMPS



Prince Manufacturing Corporation
North Sioux City, South Dakota

INDEX

PTO Hydraulic PumpP3-P7
Hydraulic Pump Accessories P8
SP-Accessories
(Repair Kits Etc.)..... See Price Book

The Hand Pumps, PM-HP-15B, PM-HP-10B and PM-HP-5B, Are In The Cylinder Section On Page C22.

PLEASE NOTE: Parts Manuals For All Standard Prince Pumps Are Available On The Prince Web Site At www.princehyd.com

PRINCE PTO HYDRAULIC PUMPS

Up to 40 gallons per minute and up to 2250 psi

UNIQUE FEATURES:

- Self-adjusting wear plates on both sides of the gears.
- Proper size hose adapters are provided for inlet ports.
- Two outlet ports are provided with a NPT adapter for one port and a plug to seal unused port.
- Center section available in high strength aluminum alloy for std. duty cycle or in high strength cast iron for high duty cycle use.

IDEAL FOR USE WITH.....

- Tractor front end loaders
- Pull-type cotton pickers
- Cotton balers (module builders)



- Tractors imported without integral hydraulics
- Landscape equipment

PLUS

STANDARD FEATURES:

- Reliable
- Efficient
- Roller Bearings
- Run fitted body
- Internally splined drive shaft.
- High-tensile cast iron end plates.
- Slips onto tractor PTO shaft (no gear box required).
- Two-bolt installation on farm tractors of all sizes.
- Rotary mowers
- Street Sweepers
- Back hoes

MODEL FEATURES

ALUMINUM CENTER HOUSING

- Standard duty cycle
- Reduced weight
- Smaller housing

CAST IRON CENTER HOUSING

- High duty cycle
- Use in circuits with motors
- Better at higher temperatures
- Increased wear resistance

REAR PORTED

- Higher flows
- Simplified hose connections
- Higher flows at reduced engine rpm as compared to other PTO pumps

Prince PTO pumps are specifically designed for PTO drive operation on all sizes of farm tractors. No additional gear box is required. Pumps are mounted by sliding the internally splined pump onto the PTO splined shaft and restraining rotation with a torque arm. See page P6 for the PTO pump torque arm kit.

• SELF ADJUSTING WEAR PLATES

Prince PTO pumps have self-adjusting wear plates that seal around the two unequal size gears. These plates, activated by internal fluid pressure, offset wear or expansion.

• FILTRATION

The pump must be used in a clean system with clean oil. The fluid cleanliness should meet the ISO 4406 17/14 level. As a minimum, 10 micron filtration is recommended.

• HYDRAULIC FLUID

A good quality mineral base hydraulic fluid with a viscosity in the 70-250 SUS range at operating temperature is recommended.

• OPERATING TEMPERATURE

Oil operating temperature should not exceed 180°F. If it does, the reservoir may be too small or a heat exchanger may be needed.

• SHAFT SPEEDS

Prince PTO pumps are designed to operate at up to 110% of standard PTO shaft speeds. Standard speeds are 540 rpm for the 6 tooth shaft and 1000 rpm for the 21 tooth shaft.

• CLOSE RUNNING CLEARANCE FOR HIGH FLOW RATE

Another feature that contributes to the excellent and long-lived efficiency of the PTO-Series pump is the minimum clearance between the gears and the center housing. Each pump is assembled with zero clearance between the housing and the tips of the gear teeth, then test run until the teeth establish a proper wear path in the housing. The result is a much tighter clearance than found in traditional pumps.

• PRESSURE RATING

Pumps are designed for 2250 PSI max. relief valve setting. A relief valve, external to the pump, must be provided in the system.

• PORTS

All pumps are provided with an inlet port adapter (SAE O-ring boss to hose barb) and outlet port adapter (SAE O-ring boss to female pipe thread) sized appropriately for the ports and required line sizes. A steel plug is provided for the second outlet port.

• RESERVOIR

As a guideline, a reservoir size in gallons should equal the pump output in gallons per minute. A larger reservoir and/or an oil cooler may be needed for high duty cycle applications.

ALUMINUM CENTER HOUSING PTO PUMPS

DIMENSIONAL DATA

PUMP MODEL	ACTUAL DISPLACEMENT	A	B	C	D	E	INLET PORTS	OUTLET PORTS ³	RECOMMENDED HOSE SIZES	DRIVE SHAFT REQUIRED	SHIP WT. (LB)
HC-PTO-1A	9.9 CI/REV	2.37	2.09	2.19	3.35	6.35	#16 SAE ¹	#12 SAE	1 1/4" IN, 3/4" OUT	1 3/8 DIA. 6 TOOTH	40
HC-PTO-9A	7.8 CI/REV	2.00	1.91	2.00	3.16	5.97	#16 SAE ¹	#12 SAE	1 1/4" IN, 3/4" OUT	1 3/8 DIA. 6 TOOTH	38
HC-PTO-2A	5.7 CI/REV	1.62	1.72	1.81	2.97	5.60	#16 SAE ²	#12 SAE	1" IN, 1/2" OUT	1 3/8 DIA. 6 TOOTH	36
HC-PTO-3A	5.7 CI/REV	1.62	1.72	1.81	2.97	5.60	#16 SAE ¹	#12 SAE	1 1/4" IN, 3/4" OUT	1 3/8 DIA. 21 TOOTH	36
HC-PTO-7A	3.6 CI/REV	1.26	1.54	1.63	2.78	5.23	#16 SAE ²	#12 SAE	1" IN, 1/2" OUT	1 3/8 DIA. 6 TOOTH	33
HC-PTO-8A	3.6 CI/REV	1.26	1.54	1.63	2.78	5.23	#16 SAE	#12 SAE	1 1/4" IN, 3/4" OUT	1 3/8 DIA. 21 TOOTH	33

1. Barbed adapter for 1 1/4" hose included. 270011013 2. Barbed adapter for 1" hose included. 270011017 3. Female pipe adaptor for 3/4" NPT included. 500204011

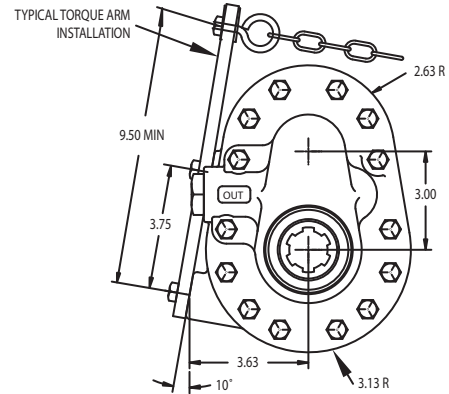
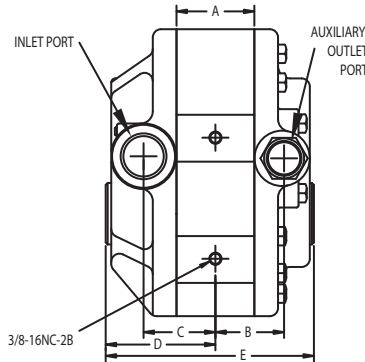
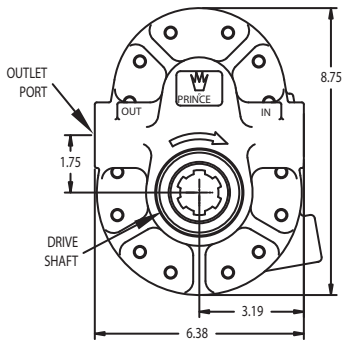

Seal kit No. for all models: PMCK-PTO-1A

CAST IRON CENTER HOUSING PTO PUMPS

DIMENSIONAL DATA

PUMP MODEL	ACTUAL DISPLACEMENT	A	B	C	D	E	INLET PORTS	OUTLET PORTS ³	RECOMMENDED HOSE SIZES	DRIVE SHAFT REQUIRED	SHIP WT. (LB)
HC-PTO-1AC	9.9 CI/REV	2.37	2.09	2.19	3.35	6.35	#16 SAE ¹	#12 SAE	1 1/4" IN, 3/4" OUT	1 3/8 DIA. 6 TOOTH	54
HC-PTO-2AC	5.7 CI/REV	1.62	1.72	1.81	2.97	5.60	#16 SAE ²	#12 SAE	1" IN, 1/2" OUT	1 3/8 DIA. 6 TOOTH	44
HC-PTO-3AC	5.7 CI/REV	1.62	1.72	1.81	2.97	5.60	#16 SAE ¹	#12 SAE	1 1/4" IN, 3/4" OUT	1 3/8 DIA. 21 TOOTH	44
HC-PTO-8AC	3.6 CI/REV	1.26	1.54	1.63	2.78	5.23	#16 SAE	#12 SAE	1 1/4" IN, 3/4" OUT	1 3/8 DIA. 21 TOOTH	42

1. Barbed adapter for 1 1/4" hose included. 270011013 2. Barbed adapter for 1" hose included. 270011017 3. Female pipe adaptor for 3/4" NPT included. 500204011

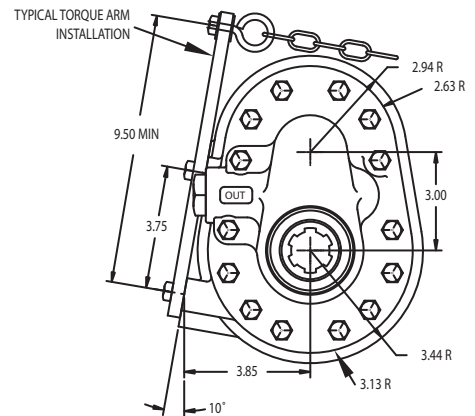
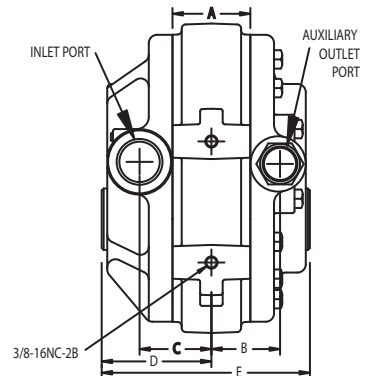
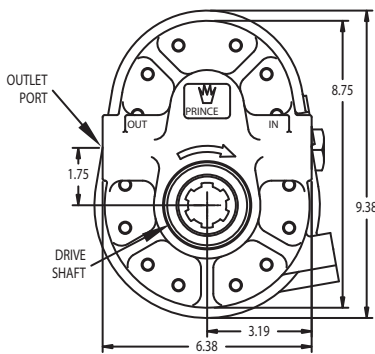

Seal kit No. for all models: PMCK-PTO-1A

PERFORMANCE DATA

PUMP MODEL	RPM	500 PSI		1000 PSI		1500 PSI		2000 PSI	
		INPUT HP	GPM OUTPUT	INPUT HP	GPM OUTPUT	INPUT HP	GPM OUTPUT	INPUT HP	GPM OUTPUT
HC-PTO-1A & HC-PTO-1AC	540	8.4	21.4	16.1	21.0	23.8	21.0	32.1	21.0
HC-PTO-9A	540	7.1	17.2	13.6	17.0	20.4	16.9	27.4	17.1
HC-PTO-2A & HC-PTO-2AC	540	4.9	12.2	9.3	11.9	13.8	11.6	18.1	11.4
HC-PTO-3A & HC-PTO-3AC	1000	9.3	23.4	17.4	23.0	25.9	22.6	34.3	22.4
HC-PTO-7A	540	2.9	7.6	5.9	7.2	8.8	7.2	11.9	7.1
HC-PTO-8A & HC-PTO-8AC	1000	5.5	14.4	11.0	13.8	16.5	13.5	22.6	13.5

NOTE: Performance values are average values. Individual pump performance may vary. Performance based on 140 SUS oil at 120° F.

PTO PUMPS

ALUMINUM CENTER HOUSING REAR PORT PTO PUMP

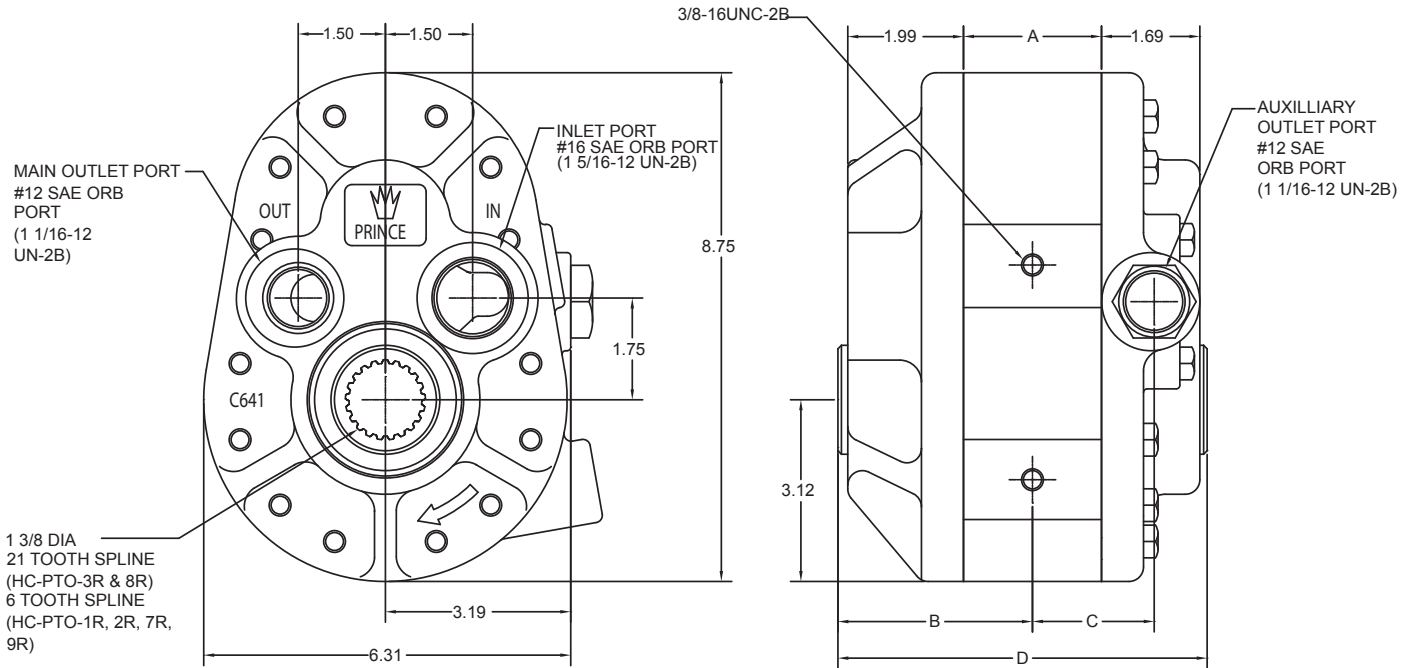

MODEL NUMBER	A	B	C	D
HC-PTO-1R	2.37	3.35	2.09	6.35
HC-PTO-9R	2.00	3.16	1.91	5.97
HC-PTO-2R	1.62	2.97	1.72	5.60
HC-PTO-3R	1.62	2.97	1.72	5.60
HC-PTO-7R	1.26	2.78	1.54	5.23
HC-PTO-8R	1.26	2.78	1.54	5.23

TYPICAL TORQUE ARM
INSTALLATION

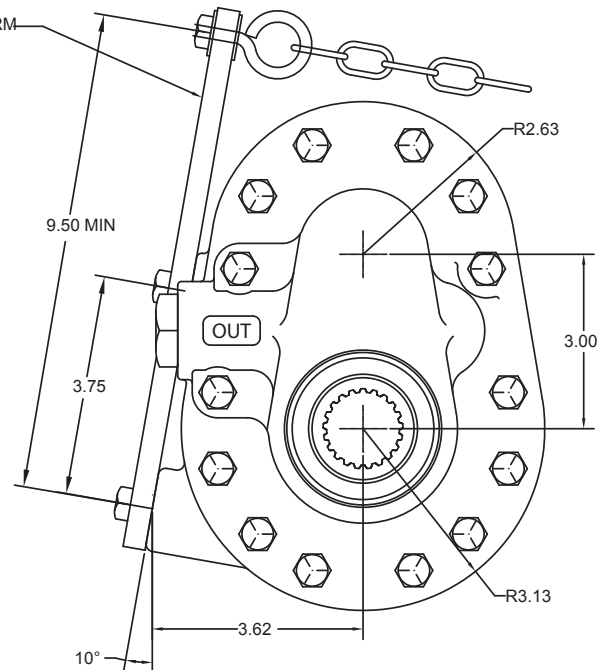

CAST IRON CENTER HOUSING REAR PORT PTO PUMP

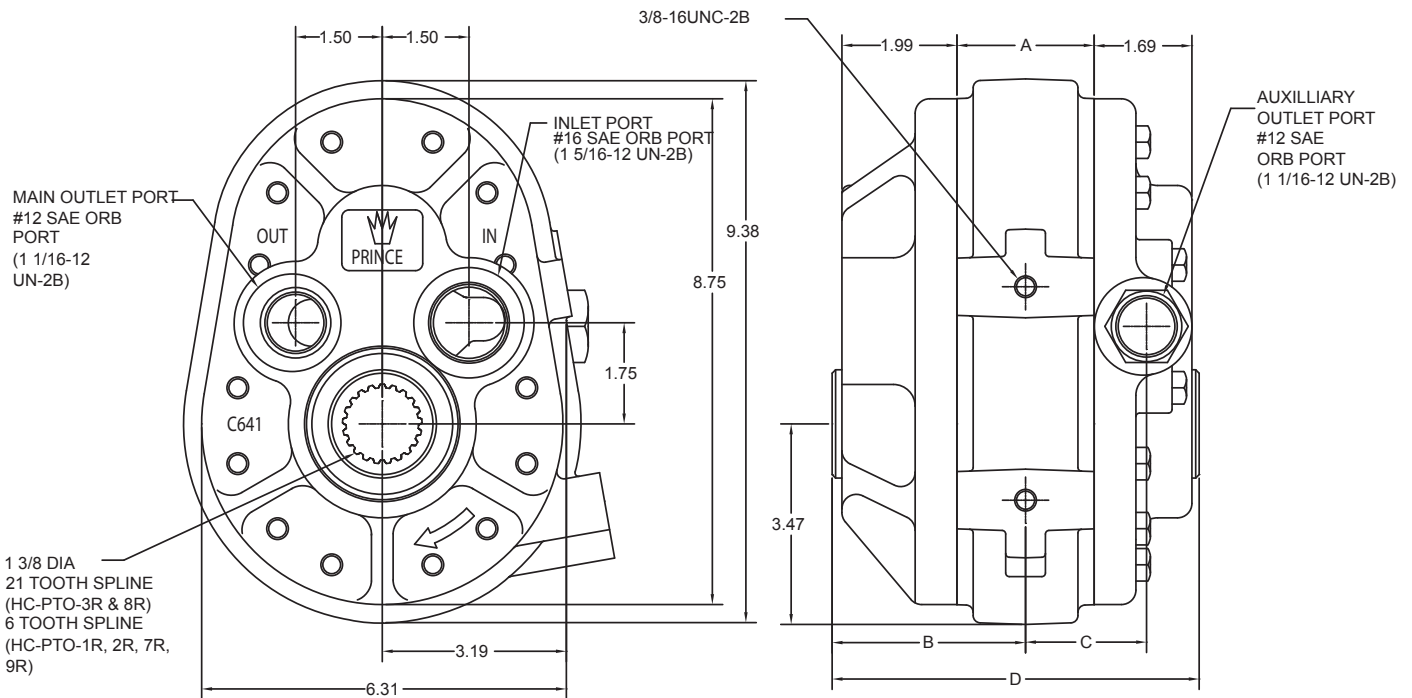

TYPICAL TORQUE ARM
INSTALLATION

MODEL NUMBER	A	B	C	D
HC-PTO-1RC	2.37	3.35	2.09	6.35
HC-PTO-9RC	2.00	3.16	1.91	5.97
HC-PTO-2RC	1.62	2.97	1.72	5.60
HC-PTO-3RC	1.62	2.97	1.72	5.60
HC-PTO-7RC	1.26	2.78	1.54	5.23
HC-PTO-8RC	1.26	2.78	1.54	5.23

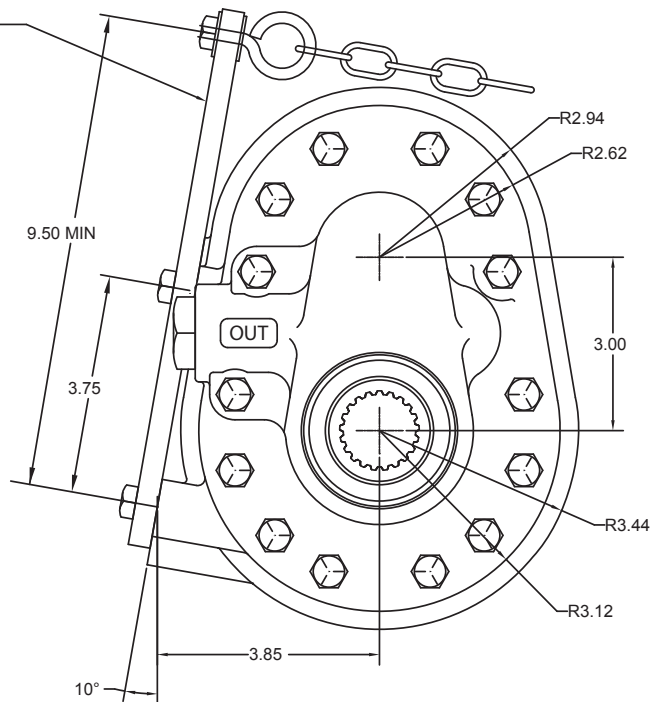

REAR PORTED PTO PUMPS

PERFORMANCE DATA

PUMP MODEL	RPM	500 PSI		1000 PSI		1500 PSI		2000 PSI	
		HP INPUT	GPM OUTPUT	HP INPUT	GPM OUTPUT	HP INPUT	GPM OUTPUT	HP INPUT	GPM OUTPUT
HC-P-K11 OR HC-P-K11C	1000	15.5	40.7	29.4	40.1	43.4	40.0	58.8	40.0
	540	8.4	21.4	16.1	21.0	23.8	21.0	32.1	21.0

NOTE: Performance values are average values. Individual pump performance may vary. Performance based on 140 SUS oil at 120° F.

SPECIFICATIONS

PUMP MODEL	ACTUAL DISP.	INLET PORT	MAIN OUTLET PORT	AUXILIARY OUTLET PORT	INLET ADAPTER	OUTLET ADAPTER	SHIP WT. (LB)
HC-P-K11 OR HC-P-K11C	9.9 CI/REV	#20 SAE O-RING (1 5/8-12UN-2B)	#16 SAE O-RING (1 5/16-12UN-2B)	#12 SAE O-RING (1 1/16-12UN-2B)	#20 SAE TO 2" HOSE BARB	#16 SAE TO 1" FEMALE PIPE	40 OR 54

SPECIAL NOTE: Recommended hose sizes for the HC-P-K11 and HC-P-K11C are 2" for the inlet line and 1" for the outlet line.

Seal kit No. for the HC-P-K11 and HC-P-K11C is: PMCK-PTO-1A.
HC-P-K11 and HC-P-K11C pumps available with 1 3/8 diameter 21 tooth spline drive only.

HC-P-K26 same as HC-P-K11 except 1 3/8"- dia. 6 tooth spline. HC-P-K26C same as HC-P-K11C except 1 3/8" dia. 6 tooth spline.
For use at 540 RPM.

ALUMINUM CENTER HOUSING (HC-P-K11)

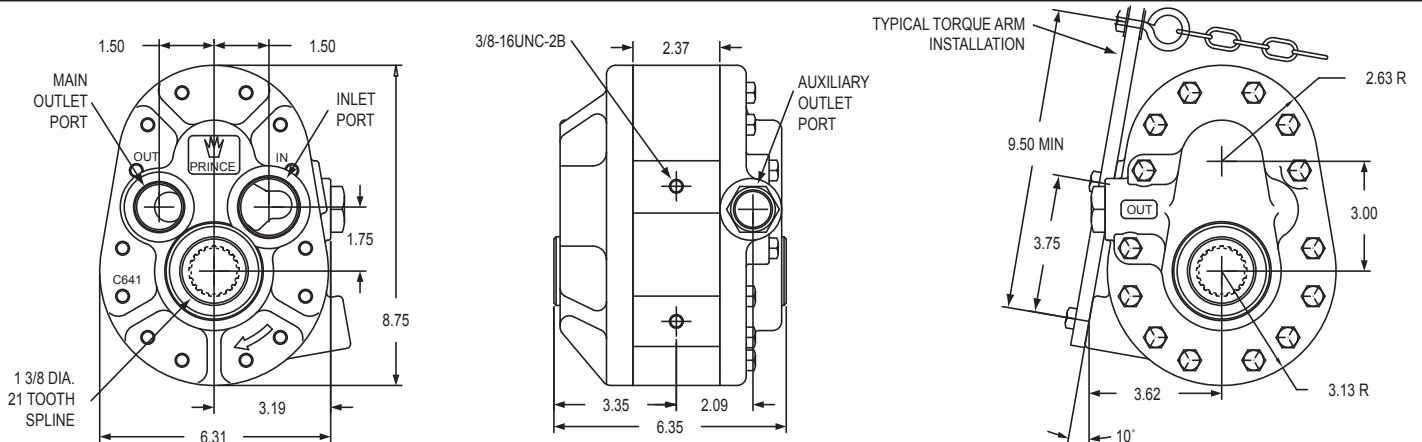

CAST IRON CENTER HOUSING (HC-P-K11C)

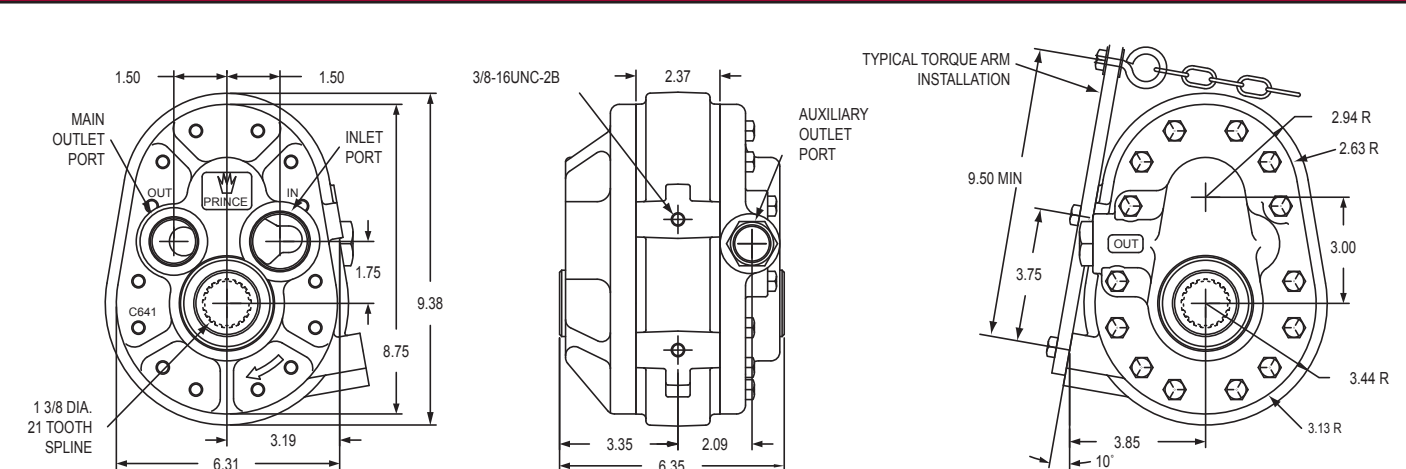

PUMP ACCESSORIES

PUMP TORQUE ARM KIT

The 180900877 torque arm kit was designed to simplify Prince PTO pump installation by eliminating the need to fabricate a custom torque arm. Items included in the kit are:

- 1-Torque arm
- 2-3/8-16 mounting bolts
- 1-Eye bolt/chain assembly

NOTE THAT TORQUE ARM KIT NO. 180900877 FITS ALL MODEL PTO PUMPS

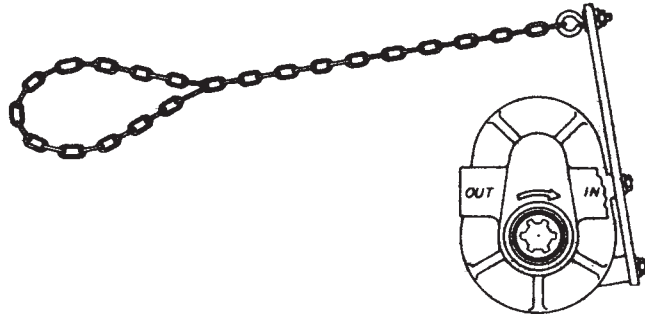

RESERVOIR BREATHER ADAPTER

The 200400039 breather adapter enables a standard Prince 10 micron spin-on filter element* to be used as a reservoir breather.

*Part Number FA10

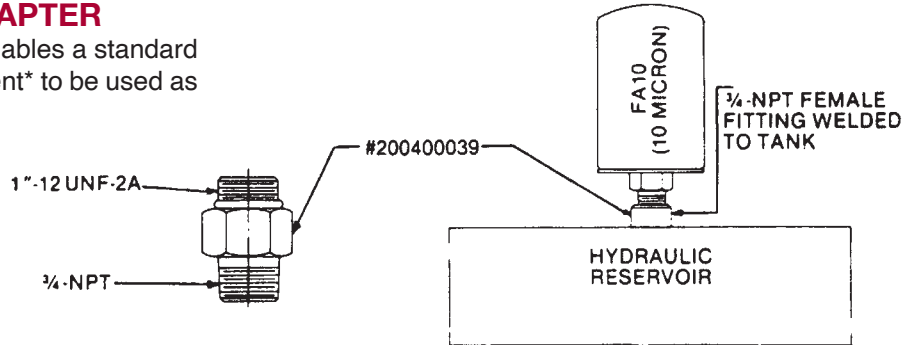

FITTINGS AND ADAPTERS

MODEL NUMBER	DESCRIPTION	CONFIGURATION
500204013	#16 SAE (1 5/16-12) Male, 1 1/4-NPTF Female	Fig. 1
500204011	#12 SAE (1 1/16-12) Male, 3/4-NPTF Female	Fig. 1
270011013	#16 SAE (1 5/16-12) Male, 1 1/4 Hose Barb	Fig. 2
270011017	#16 SAE (1 5/16-12) Male, 1 Hose Barb	Fig. 2
270011046	#20 SAE (1 5/8-12) Male, 2 Hose Barb	Fig. 2
500204012	#16 SAE (1 5/16-12) Male, 1-NPTF Female	Fig. 1

FIG. 1

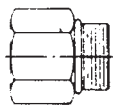

FIG. 2

