



THE SWORD LINE

ALL PURPOSE LINE

THE "SWORD" Welded-DA-Heavy Duty-3000 PSI



FEATURES:

- Skived/honed tubing
- Heavy duty welded construction
- Chromed, ground & polished piston rod
- Ductile iron piston, gland & clevis, cast steel base end
- Urethane u-cup & urethane wiper in gland, crown seal on piston
- Square ring gland retainer provides positive lock
- Pins, clips & cotters included
- Standard color is black
- Stroke control may be installed on 8" strokes

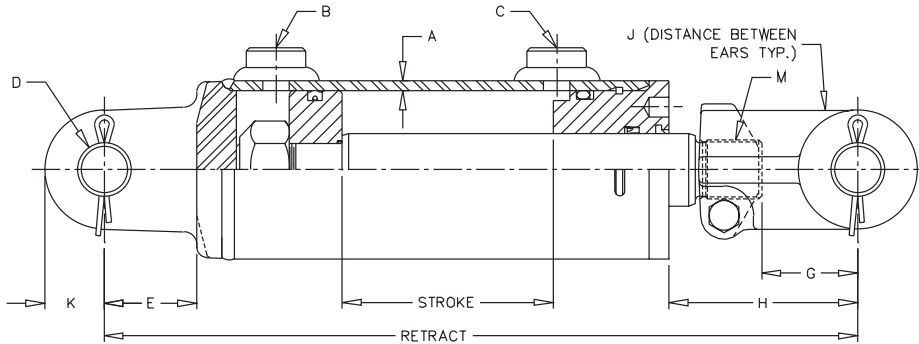

Rods are sized for a maximum safe push load (2:1 safety factor) given in the table. This is based on the pin configuration shown with no center support.

Model No.	Style	Wt.	PSI	Column Load (Lbs.)	Retract	Rod Dia.	A	B SAE	C SAE	D	E	G	H	J	K	M
SAE-19408*	1 1/2 x 8	13	3000	FULL PSI	20 1/4	3/4	3/16	#6	#6	.765	2 5/8	2 5/8	5 1/4	5/8	3/4	-
SAE-19410*	1 1/2 x 10	14	3000	4,600 LBS	20 1/4	3/4	3/16	#6	#6	.765	2 5/8	2 5/8	3 1/4	5/8	3/4	-
SAE-19412*	1 1/2 x 12	16	3000	3,525 LBS	22 1/4	3/4	3/16	#6	#6	.765	2 5/8	2 5/8	3 1/4	5/8	3/4	-
SAE-19416*	1 1/2 x 16	20	3000	1,525 LBS	31 1/2	3/4	3/16	#6	#6	.765	2 5/8	2 5/8	8 1/2	5/8	3/4	-
SAE-42008	2 x 8	19	3000	FULL PSI	20 1/4	1 1/8	3/16	#8	#8	1.015	1 3/4	1 13/16	5 9/16	1 1/16	1	1 1/8-12
SAE-42010	2 x 10	20	3000	FULL PSI	20 1/4	1 1/8	3/16	#8	#8	1.015	1 3/4	1 13/16	3 9/16	1 1/16	1	1 1/8-12
SAE-42012	2 x 12	22	3000	FULL PSI	22 1/4	1 1/8	3/16	#8	#8	1.015	1 3/4	1 13/16	3 9/16	1 1/16	1	1 1/8-12
SAE-42016	2 x 16	25	3000	FULL PSI	31 1/2	1 1/8	3/16	#8	#8	1.015	1 3/4	1 13/16	8 13/16	1 1/16	1	1 1/8-12
SAE-42020	2 x 20	28	3000	7,575 LBS	30 1/4	1 1/8	3/16	#8	#8	1.015	1 3/4	1 13/16	3 9/16	1 1/16	1	1 1/8-12
SAE-42024	2 x 24	31	3000	5,600 LBS	34 1/4	1 1/8	3/16	#8	#8	1.015	1 3/4	1 13/16	3 9/16	1 1/16	1	1 1/8-12
SAE-42508	2 1/2 x 8	21	3000	FULL PSI	20 1/4	1 1/4	3/16	#8	#8	1.015	1 3/4	1 13/16	5 9/16	1 1/16	1	1 1/8-12
SAE-42510	2 1/2 x 10	22	3000	FULL PSI	20 1/4	1 1/4	3/16	#8	#8	1.015	1 3/4	1 13/16	3 9/16	1 1/16	1	1 1/8-12
SAE-42512	2 1/2 x 12	23	3000	FULL PSI	22 1/4	1 1/4	3/16	#8	#8	1.015	1 3/4	1 13/16	3 9/16	1 1/16	1	1 1/8-12
SAE-42516	2 1/2 x 16	27	3000	10,800 LBS	31 1/2	1 1/4	3/16	#8	#8	1.015	1 3/4	1 13/16	8 13/16	1 1/16	1	1 1/8-12
SAE-42520	2 1/2 x 20	31	3000	11,700 LBS	30 1/4	1 1/4	3/16	#8	#8	1.015	1 3/4	1 13/16	3 9/16	1 1/16	1	1 1/8-12
SAE-42524	2 1/2 x 24	35	3000	8,600 LBS	34 1/4	1 1/4	3/16	#8	#8	1.015	1 3/4	1 13/16	3 9/16	1 1/16	1	1 1/8-12
SAE-43008	3 x 8	23	3000	FULL PSI	20 1/4	1 3/8	3/16	#8	#8	1.015	1 3/4	1 13/16	5 9/16	1 1/16	1 1/8	1 1/8-12
SAE-43010	3 x 10	26	3000	FULL PSI	20 1/4	1 3/8	3/16	#8	#8	1.015	1 3/4	1 13/16	3 9/16	1 1/16	1 1/8	1 1/8-12
SAE-43012	3 x 12	28	3000	FULL PSI	22 1/4	1 3/8	3/16	#8	#8	1.015	1 3/4	1 13/16	3 9/16	1 1/16	1 1/8	1 1/8-12
SAE-43016	3 x 16	33	3000	16,900 LBS	31 1/2	1 3/8	3/16	#8	#8	1.015	1 3/4	1 13/16	8 13/16	1 1/16	1 1/8	1 1/8-12
SAE-43020	3 x 20	39	3000	17,300 LBS	30 1/4	1 3/8	3/16	#8	#8	1.015	1 3/4	1 13/16	3 9/16	1 1/16	1 1/8	1 1/8-12
SAE-43024	3 x 24	43	3000	12,800 LBS	34 1/4	1 3/8	3/16	#8	#8	1.015	1 3/4	1 13/16	3 9/16	1 1/16	1 1/8	1 1/8-12
SAE-43508	3 1/2 x 8	29	3000	FULL PSI	20 1/4	1 1/2	3/16	#8	#8	1.015	1 3/4	1 13/16	5 3/8	1 1/8	1 1/4	1 1/2-12
SAE-43510	3 1/2 x 10	31	3000	FULL PSI	20 1/4	1 1/2	3/16	#8	#8	1.015	1 3/4	1 13/16	3 3/8	1 1/8	1 1/4	1 1/2-12
SAE-43512	3 1/2 x 12	33	3000	FULL PSI	22 1/4	1 1/2	3/16	#8	#8	1.015	1 3/4	1 13/16	3 3/8	1 1/8	1 1/4	1 1/2-12
SAE-43516	3 1/2 x 16	38	3000	24,200 LBS	31 1/2	1 1/2	3/16	#8	#8	1.015	1 3/4	1 13/16	8 3/8	1 1/8	1 1/4	1 1/2-12
SAE-43520	3 1/2 x 20	43	3000	24,700 LBS	30 1/4	1 1/2	3/16	#8	#8	1.015	1 3/4	1 13/16	3 3/8	1 1/8	1 1/4	1 1/2-12
SAE-43524	3 1/2 x 24	48	3000	18,250 LBS	34 1/4	1 1/2	3/16	#8	#8	1.015	1 3/4	1 13/16	3 3/8	1 1/8	1 1/4	1 1/2-12
SAE-44008	4 x 8	40	3000	FULL PSI	20 1/4	1 3/4	3/16	#8	#8	1.015	1 3/4	1 13/16	5 3/8	1 1/8	1 1/4	1 1/2-12
SAE-44010	4 x 10	43	3000	FULL PSI	20 1/4	1 3/4	3/16	#8	#8	1.015	1 3/4	1 13/16	3 3/8	1 1/8	1 1/4	1 1/2-12
SAE-44012	4 x 12	45	3000	FULL PSI	22 1/4	1 3/4	3/16	#8	#8	1.015	1 3/4	1 13/16	3 3/8	1 1/8	1 1/4	1 1/2-12
SAE-44016	4 x 16	54	3000	FULL PSI	31 1/2	1 3/4	3/16	#8	#8	1.015	1 3/4	1 13/16	8 3/8	1 1/8	1 1/4	1 1/2-12
SAE-44020	4 x 20	58	3000	FULL PSI	30 1/4	1 3/4	3/16	#8	#8	1.015	1 3/4	1 13/16	3 3/8	1 1/8	1 1/4	1 1/2-12
SAE-44024	4 x 24	60	3000	33,525 LBS	34 1/4	1 3/4	3/16	#8	#8	1.015	1 3/4	1 13/16	3 3/8	1 1/8	1 1/4	1 1/2-12
SAE-44030	4 x 30	65	3000	22,900 LBS	40 1/4	1 3/4	3/16	#8	#8	1.015	1 3/4	1 13/16	3 3/8	1 1/8	1 1/4	1 1/2-12

*Uses formed clevis & 3/4" pin.