

# SP SERIES HYDRAULIC GEAR PUMP

## OUTSTANDING FEATURES

• **Patented Non-Symmetrical Gears** The adoption of non-symmetrical gears insures greater power per unit volume compared with pumps of conventional design. The compact gear compartment has enabled high-pressure operation. The increased number of gear teeth has reduced the flow pulsation and minimized the noise.

U.S.A.	Patent No.	3817117	
U.K.	Patent No.	1400577	
French	Patent No.	7230448	
German	Patent No.	7231801	Others: Pending

- **Bearings** PTFE composite bearings are used due to the ability to handle heavy loads, low shaft speeds, and high levels of contamination. Engineering tests on the PTFE bearings indicate they will withstand bearing loads over twice as high as conventional steel backed aluminum bearings used in many pumps. The PTFE resin layer will absorb a high degree of contamination with out damage to the pump. Also since the PTFE layer is self lubricating, contamination from bearing wear in high load situations (when no oil film is present) is reduced. The side benefit from reduced friction under all conditions is a reduced consumption of power.
- **Gears and drive shaft** are hardened alloy steel of one piece construction.
- **Special gear design:** Non-symmetrical gear insures low noise and compactness.
- **Highest Quality Workmanship.**
- **Pressures Up To 3000 P.S.I.**
- **Dependable service:** Balanced pressure loading insures small dispersion, good durability and maintains high performance.
- **Extremely Efficient.**
- **Perfect alignment:** "Through bore" design provides perfect alignment of pump element and assures even bearing load.
- **With the aluminum alloy casing,** the SP Series features light weight and easy handling.

- **Double pumps:** Available in SP20, SP25 and SP25/SP20 Combinations.
- **Maximum speed** from 3000 to 4000 RPM using SAE 10W oil.
- **Displacement covers** .400 in<sup>3</sup>/rev. to 3.869 in<sup>3</sup>/rev.
- **Inlet pressure:** Pump inlet should not exceed 5 in. of mercury vacuum or 14 P.S.I. positive pressure.
- **Ports:** SAE straight thread O-ring boss for SP20 & SP25. Other Ports available - consult factory. (Taper pipe threads not available).
- **Working oil:** A mineral based oil with additives to resist corrosion, oxidation, and foaming is recommended. Viscosity at any running condition should be 60 SUS minimum and 250 SUS maximum. 180° F is the maximum recommended system operating temperature.
- **Filtration:** Per ISO cleanliness code level 17/14. As a minimum, 10 micron filtration is recommended.

## INTERNAL COMPONENTS BREAKDOWN

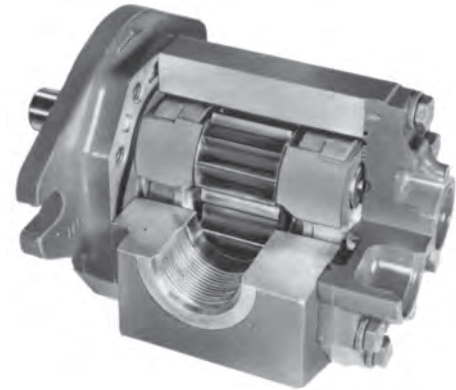

## SP20 SERIES HYDRAULIC PUMPS AND NOISE GENERATION

The accompanying graphs show the typical Pump Sound Pressure Ratings (PSPR, A-weighted Sound Pressure Levels) for the SP20 Series Hydraulic Pumps. The Pump Sound Pressure Ratings (PSPR) shown below in the graphs were computed and determined using Sound Intensity Analysis Methods. Sound Intensity Analysis provides the most accurate and reliable data for predicting and comparing a Pump Sound Pressure Rating (A-weighted Sound Pressure Level), for a pump exposed to various operating and environmental conditions.

Pumps tested below in the graphs were tested as defined by **ANSI/B93.71M**, (Hydraulic fluid power-Pumps-Test code for the determination of airborne noise levels) in a semi-anechoic room. For free-field conditions (i.e. such as a noise source located above the ground in a open area), pump sound pressure ratings (A-weight Sound Pressure Levels) may be estimated by subtracting 3dB(A) from the values shown on the graphs.

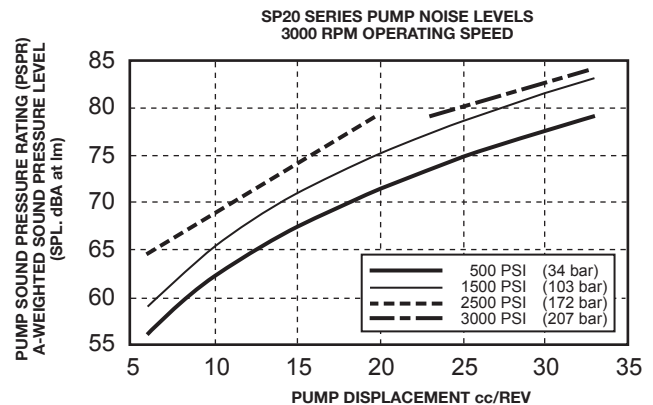
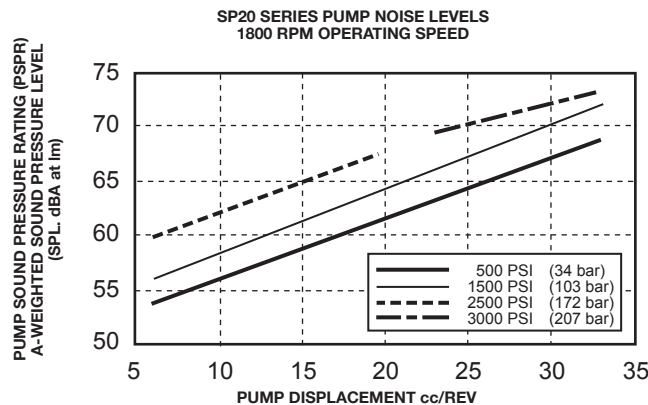

Pump acoustical data was determined in accordance with ANSI/B93.71M. Hydraulic fluid power-Pumps-Test code for the determination of airborne noise levels

## SP20 SERIES SAE "A" FLANGE PUMP



The SP20B pump now utilizes self-lubricating thrust blocks that eliminate the need for separate wear plates. They are made from a high strength aluminum alloy with exceptional anti-galling properties. This new thrust block design also incorporates advanced bearings designed specifically for high pressure hydraulic pumps. This new bearing features a robust fluoropolymer PTFE wear surface that yields unsurpassed load carrying capabilities and cavitation resistance even at low speeds and moderate levels of contamination. Also, since the PTFE resin layer is self-lubricating, contamination from bearing wear in high load situations (when no oil film is present) is reduced. This new thrust block design combined with these advanced bearing results in lower friction and less internal oil loss resulting in higher pump efficiencies.

### MODEL CODE

**SP20B 14 A 9 H 2-R**

<p><b>SERIES NO</b> _____</p> <p><b>DISPLACEMENT CODE (CC/REV)</b> _____</p> <p><b>PORT LOCATION</b> _____</p> <p>A-SIDE INLET AND OUTLET C-BOTH SIDE AND REAR W/STEEL PLUGS D-REAR INLET AND OUTLET E-BOTH SIDE AND REAR W/PLASTIC PLUGS</p> <p><b>PORT TYPE</b> _____</p> <p>9-STANDARD PORTS SAE PER CHART BELOW OPTIONAL PORTS CONSULT FACTORY SIDE PORT ONLY 8-METRIC O-RING 7-BSPP 6-SAE SPLIT FLANGE 16-33 CC ONLY 5-METRIC SPLIT FLANGE 16-33 CC ONLY</p>	<p><b>ROTATION (FACING END OF SHAFT)</b> L-COUNTER CLOCKWISE R-CLOCKWISE DRIVE SHAFT</p> <p><b>DRIVE SHAFT</b> 9-SAE 9 TOOTH 16/32 SPLINE 2-SAE 5/8" STRAIGHT KEYED 3-11 TOOTH 16/32 SPLINE* 4-3/4" STRAIGHT KEYED* 5-SAE 10 TOOTH 16/32 SPLINE</p> <p><b>MOUNTING</b> H-SAE "A" 2 BOLT</p>	<p>*REQUIRED FOR DISPLACEMENT CODES 30 AND 33</p>
---------------------------------------------------------------------------------------------------------------------------------------------------------------------------------------------------------------------------------------------------------------------------------------------------------------------------------------------------------------------------------------------------------------------------------------------------------------------------------------------------	-----------------------------------------------------------------------------------------------------------------------------------------------------------------------------------------------------------------------------------------------------------------------------------------------------------------------------	---------------------------------------------------

### SP20 STANDARD STOCK MODELS

SP20B06A9H2-R	SP20B09A9H2-L	SP20B14A9H4-L	SP20B16A9H9-R	SP20B23A9H9-R
SP20B06A9H3-R	SP20B09A9H2-R	SP20B14A9H9-R	SP20B16D9H3-R	SP20B27A9H2-R
SP20B06A9H9-R	SP20B09A9H4-R	SP20B14D9H4-L	SP20B20A9H2-R	SP20B27A9H9-R
SP20B08A9H2-L	SP20B11A9H2-R	SP20B14D9H9-R	SP20B20A9H4-L	SP20B33D9H3-LH
SP20B08A9H2-R	SP20B11A9H4-R	SP20B16A9H2-L	SP20B20A9H9-L	
SP20B08A9H4-R	SP20B11A9H9-R	SP20B16A9H2-R	SP20B20A9H9-R	
SP20B08A9H9-L	SP20B14A9H2-R	SP20B16A9H4-R	SP20B23A9H2-R	

### SPECIFICATIONS

MODEL NUMBER	DISP. IN <sup>3</sup> /REV	RATED PRESSURE (PSI)	MAX <sup>o</sup> RPM	A	B	INLET PORT			OUTLET PORT		FULL THREAD DEPTH	WT. (LB.)
						SAE SIZE		FULL THREAD DEPTH	SAE SIZE			
						SIDE	REAR		SIDE	REAR		
SP20B06	.400	3000	4000	1.79	4.22	7/8-14 UN-2B	1 5/16-12 UN-2B	5/8"	3/4-16 UN-2B	1/16-12 UN-2B	9/16"	5.0
SP20B08	.499	3000	4000	1.83	4.30	1 1/16-12 UN-2B	1 5/16-12 UN-2B	3/4"	7/8-14 UNF-2B	1 1/16-12 UN-2B	5/8"	5.1
SP20B09	.589	3000	4000	1.87	4.38							5.3
SP20B11	.677	3000	4000	1.91	4.46							5.5
SP20B14	.860	3000	4000	1.99	4.62							5.7
SP20B16	.976	3000	4000	2.04	4.71	1 5/16-12 UN-2B	1 5/16-12 UN-2B	3/4"	1 1/16-12 UN-2B	3/4"	6.0	
SP20B20	1.220	3000	3500	2.15	4.93						6.2	
SP20B23	1.403	2500	3500	2.23	5.09	UN-2B	UN-2B	3/4"	UN-2B	3/4"	6.4	
SP20B27	1.654	2500	3500	2.34	5.31						6.6	
SP20B33	2.014	2500	3500	2.49	5.62						7.6	

<sup>o</sup>Max. RPM for side ported models. Rear ported models should be restricted to 21 gpm. Standard Seal Kit for all SP20 Models is Prince Part No. PMCK-SP20.

## SP20 SERIES DIMENSIONAL DATA

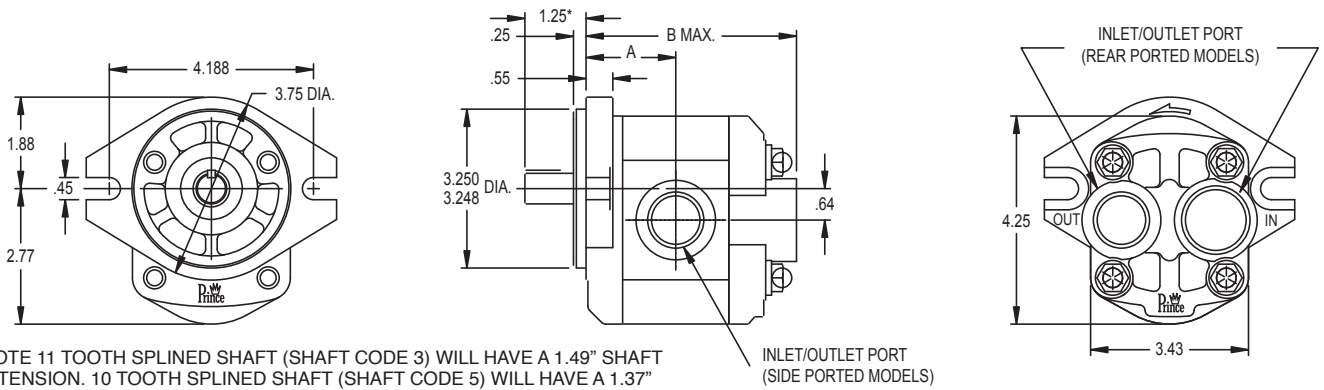

\*NOTE 11 TOOTH SPLINED SHAFT (SHAFT CODE 3) WILL HAVE A 1.49" SHAFT EXTENSION. 10 TOOTH SPLINED SHAFT (SHAFT CODE 5) WILL HAVE A 1.37" SHAFT EXTENSION.

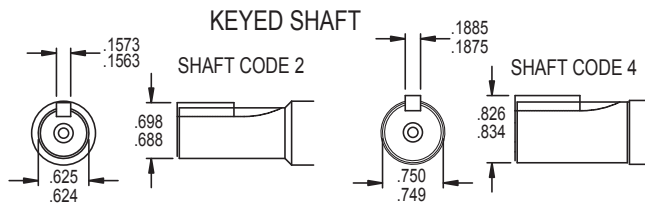

### SPLINED SHAFT

SHAFT CODE 9	SHAFT CODE 5	SHAFT CODE 3
9 TOOTH	10 TOOTH	11 TOOTH
16/32 DP	16/32 DP	16/32 DP
30° PA	30° PA	30° PA
FLAT ROOT SIDE FIT	FLAT ROOT SIDE FIT	FLAT ROOT SIDE FIT

## TYPICAL PERFORMANCE DATA

MODEL		RPM								PRESSURE (PSI)
		500	1000	1500	2000	2500	3000	3500	4000	
SP20B06	FLOW (GPM)	.78	1.62	2.48	3.35	4.24	5.10	5.98	6.92	3000
	INPUT HORSE POWER	1.85	3.77	5.66	7.57	9.45	11.13	13.06	14.80	
SP20B08	FLOW (GPM)	.88	1.91	2.97	4.04	5.10	6.16	7.27	8.33	
	INPUT HORSE POWER	2.23	4.38	6.53	8.83	11.13	13.57	16.17	18.69	
SP20B09	FLOW (GPM)	1.03	2.30	3.52	4.75	5.97	7.19	8.46	9.74	
	INPUT HORSE POWER	2.61	5.03	7.54	10.14	12.84	15.54	18.43	21.31	
SP20B11	FLOW (GPM)	1.27	2.74	4.16	5.63	7.05	8.51	9.98	11.40	
	INPUT HORSE POWER	2.98	5.77	8.75	11.63	14.80	17.87	21.12	24.38	
SP20B14	FLOW (GPM)	1.61	3.36	5.19	7.01	8.91	10.74	12.56	14.39	
	INPUT HORSE POWER	3.68	7.09	10.51	14.19	18.00	21.68	25.49	29.43	
SP20B16	FLOW (GPM)	1.80	3.82	5.87	7.93	9.98	12.11	14.24	16.22	
	INPUT HORSE POWER	4.01	7.86	11.87	15.87	20.17	24.33	28.78	34.12	
SP20B20	FLOW (GPM)	2.35	4.92	7.49	10.05	12.70	15.26	17.76		
	INPUT HORSE POWER	5.21	9.98	14.89	20.10	25.16	30.52	35.73		
SP20B23	FLOW (GPM)	2.80	5.72	8.73	11.60	14.68	17.61	20.55		
	INPUT HORSE POWER	5.06	9.68	14.44	19.21	24.27	29.48	34.54		
SP20B27	FLOW (GPM)	3.30	6.90	10.47	13.90	17.52	20.94	24.46		
	INPUT HORSE POWER	5.98	11.59	17.20	23.00	28.98	34.78	41.13		
SP20B33	FLOW (GPM)	4.13	8.47	12.60	16.86	21.11	25.26	29.52		
	INPUT HORSE POWER	7.14	13.40	19.98	27.04	33.90	41.05	47.89		
										2500

Typical Performance Data Based on 140 SUS Oil at 120° F