

PRESSURE COMPENSATED ADJUSTABLE FLOW CONTROL VALVES

MODEL RD-100 TOP PORT FLOW CONTROL



MODEL RD-1900 SIDE PORT FLOW CONTROL



The PRINCE valve models RD-100 and RD-1900 are pressure compensated adjustable flow control valves. By rotating the handle, the flow out the "CF", or controlled flow port, can be varied from approximately 0 to the maximum controlled flow shown in the chart below. Any remaining flow is bypassed to the "EF" or excess flow port. This flow can be used to power another circuit or can be returned to tank. Once the controlled flow is set it will remain nearly constant with variations in pressure on either the controlled or excess flow ports.

Please note: If during operation the controlled flow port is blocked the valve will compensate in such a way as to shut off flow to the excess port.

These valves can also be used as a restrictive flow control by plugging the excess flow port.

The PRINCE valve models RDRS-100 and RDRS-1900 have a built in adjustable pressure relief. For these models the excess flow port **must** be connected to tank.

It should be noted that whenever these or any valve is used to bypass or restrict, flow heat will be generated. Steps may be required to keep oil temperature from becoming too high.

VALVE SPECIFICATIONS:

Capacity: 30 gpm max inlet flow
Pressure: 3000 psi max
Weight: RD-100 8 lbs.
RD-1900 9 lbs.

FIELD REPAIR KITS:

Handle hardware 660301002
Seal Kit 660501001

STANDARD MODELS AVAILABLE

MODEL NUMBER		PORT SIZES	CONTROLLED FLOW RANGE	For Other Relief Settings Please Specify:
RD-137-8	RD-1937-8	3/8 NPTF	0-8 GPM	
RD-150-8	RD-1950-8	1/2 NPTF	0-8 GPM	
RD-150-16	RD-1950-16	1/2 NPTF	0-16 GPM	
RD-175-16	RD-1975-16	3/4 NPTF	0-16 GPM	
RD-175-30	RD-1975-30	3/4 NPTF	0-30 GPM	
RD-108-8	RD-1908-8	#8 SAE	0-8 GPM	
RD-112-30	RD-1912-30	#12 SAE	0-30 GPM	
RDRS-150-16	RDRS-1950-16	1/2 NPTF	0-16 GPM	These models have built in relief set at 1500 psi @ 10 GPM.
RDRS-175-30	RDRS-1975-30	3/4 NPTF	0-30 GPM	

Special combinations of port size and controlled flow range are available in O E M quantities.
Please consult your sales representative.

SYMBOL

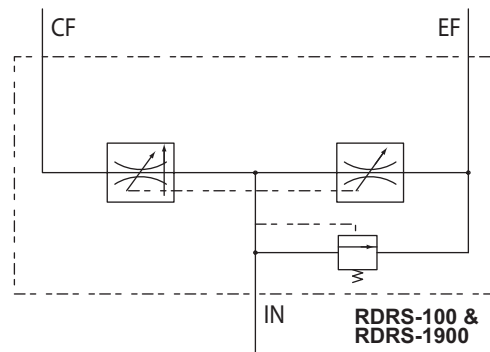
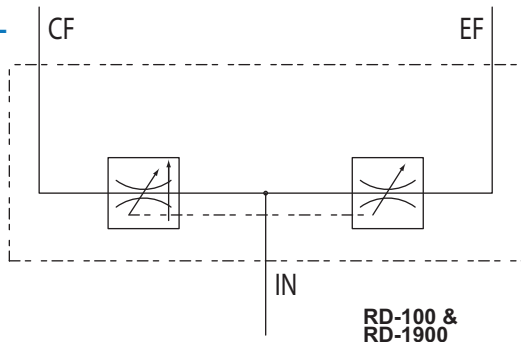

MODEL RD-100 AND RD-1900 PARTS BREAKDOWN AND DIMENSIONS

MODEL RD-100

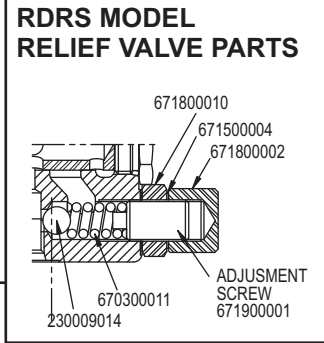
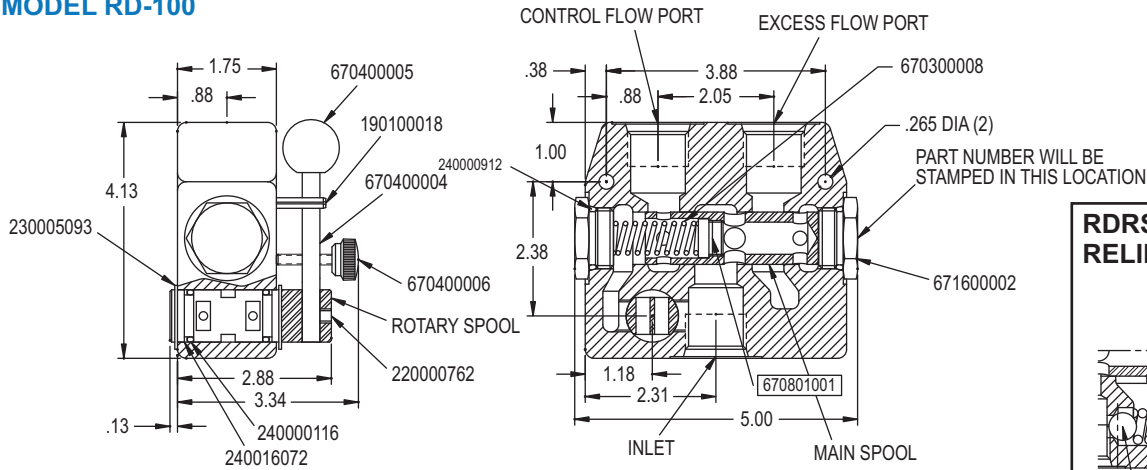

MODEL RD-1900

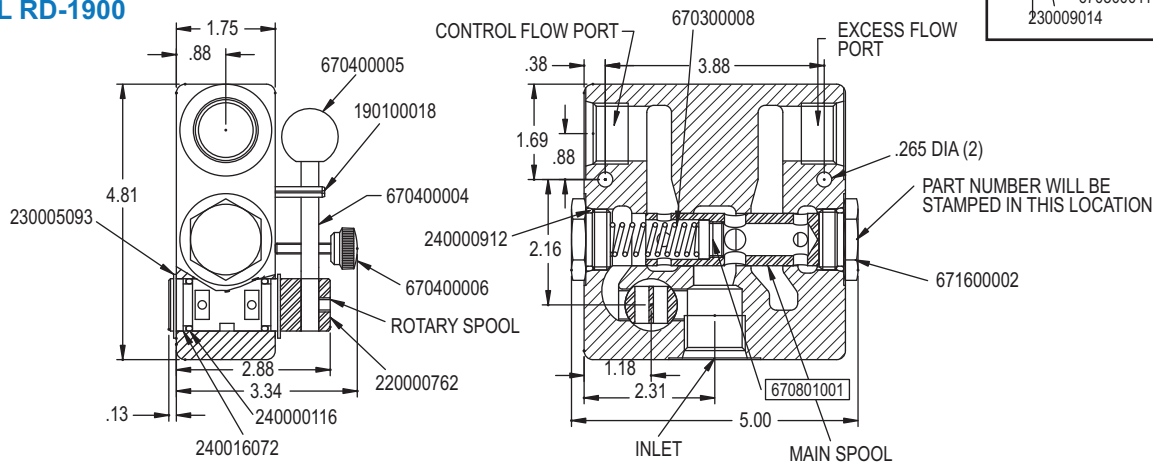

APPLICATIONS:

As illustrated in the circuit below the RD-100/RD-1900 adjustable flow control valves can be used to control the speed of a hydraulic motor. In this circuit oil from a source is directed into the inlet of the valve. By moving the handle the flow can be varied from approximately zero when handle is vertical to maximum when the handle is horizontal. Oil not going to the controlled flow port is bypassed to the excess flow port where it can be used to supply another circuit

or returned to tank. Instead of the control flow directly supplying a motor it can be used as an adjustable priority divider and provide adjustable priority flow to a directional control valve bank. Also as illustrated the RD-100/RD-1900 can be used as a restrictive type flow control. In this circuit the excess flow port is blocked. This would normally be used with a pressure compensated pump or in a closed center system.

BYPASS FLOW CIRCUIT

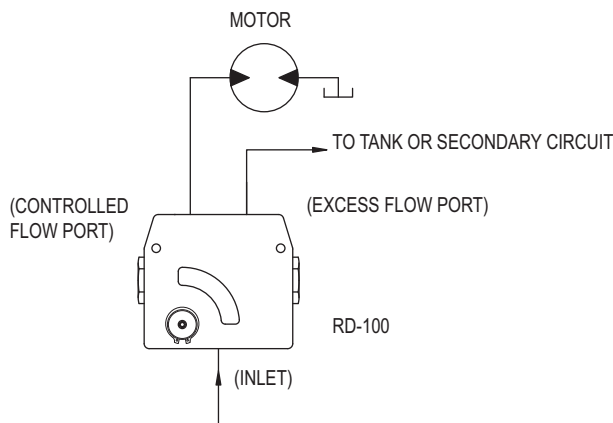

RESTRICTIVE FLOW CIRCUIT

