

# LVS

## LVS SPECIFICATIONS:

MAX. OPERATING PRESSURE.....3000 PSI  
 MAX. OPERATING TEMP.....180°F  
 RECOMMENDED FILTRATION.....10 MICRON  
 FLOW RATING.....11 GPM MAX  
 WEIGHT.....17 LBS  
 SERIES CIRCUIT CONSTRUCTION

### POWER BEYOND OPTION A

FOR TOP PORTED POWER BEYOND APPLICATION ONLY, INSTALL THIS PLUG INSIDE VALVE BODY. CONNECT POWER BEYOND PORT TO THE DOWN STREAM VALVE AND THE TANK PORT TO THE RESERVOIR. FOR OPEN CENTER APPLICATIONS DISCARD PLUG AND PUT A STEEL PLUG IN POWER BEYOND PORT.

### POWER BEYOND OPTION B

TANK PORT

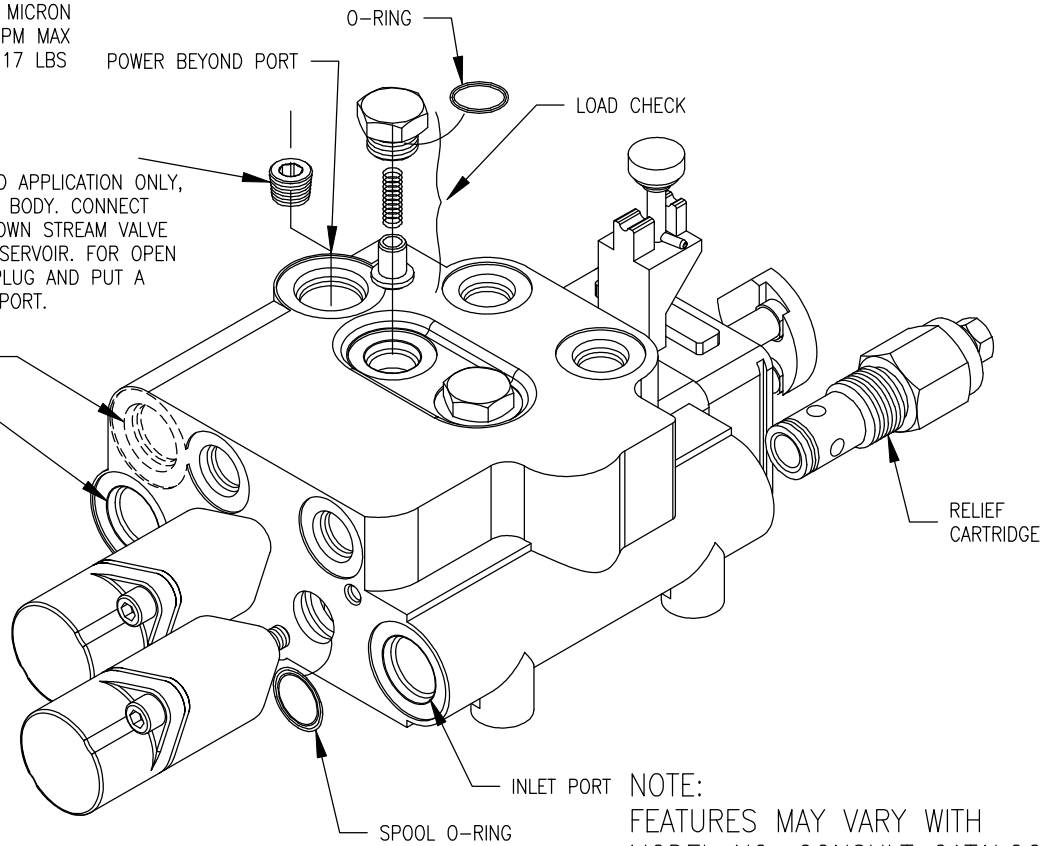

NOTE:  
 FEATURES MAY VARY WITH  
 MODEL NO. CONSULT CATALOG

### POWER BEYOND OPTION 'A':

Install pipe plug inside valve body. The power beyond port is connected to the downstream valve. Please note the tank port of the LVS must be connected to tank. This option can be converted to standard open center by removing pipe plug and plugging unused port.

### POWER BEYOND OPTION 'B':

Rear power beyond port. Pipe plug is not included.

### LOAD CHECK DESCRIPTION:

The load check feature is standard on all LVS series valves. Each spool has a separate load check. The load check will prevent the fall of a cylinder as the spool is shifted. It also prevents the backflow of oil from the work port to the inlet. The pump must build up enough pressure to overcome the pressure on the work port caused by the weight of the load before the cylinder can move.

PLEASE NOTE that the load check has nothing to do with how well the valve will hold up a cylinder with that spool in neutral. The load check is functional only when that spool is shifted.

## LVS KITS AND CARTRIDGES

PART NO.	DESCRIPTION
660590029	SEAL KIT, LVS
660180170	SPRING CENTER W/FLOAT DETENT KIT (A-B SPOOL)
660180169	SPRING CENTER W/REGEN KIT (C-D SPOOL)
660180173	SPRING CENTER KIT (EITHER SPOOL)
660280004	NO-RELIEF PLUG (OPTION 1)
660280009	ADJUSTABLE RELIEF CARTRIDGE, 1500-3000 PSI (OPTION 5)
270006122	ADJUSTABLE RELIEF CART. P.O., 500-3000 PSI (OPTION 6)
660180167	JOYSTICK ASSY (MOUNTING FEET TO THE LEFT)
660180164	SPOOL LOCK JOYSTICK ASSY (MOUNTING FEET TO THE LEFT)
660180157	JOYSTICK ASSY (MOUNTING FEET DOWN/TO REAR)
660180153	SPOOL LOCK JOYSTICK ASSY (MOUNTING FEET DOWN/TO REAR)

RELIEF OPTION 6 USES A DIFFERENT CAVITY DETAIL THAN OPTIONS 1 THRU 5 AND IS NOT INTERCHANGEABLE. TO ADJUST RELIEF PRESSURE, LOOSEN JAM NUT AND TURN SET SCREW CLOCKWISE TO INCREASE PRESSURE AND/OR COUNTER-CLOCKWISE TO DECREASE. A PRESSURE GAUGE MUST BE INSTALLED IN THE INLET LINE WHENEVER THE RELIEF PRESSURE IS ADJUSTED.



**WARNING:** OVERPRESSURE MAY CAUSE SUDDEN AND UNEXPECTED FAILURE OF A COMPONENT IN THE HYDRAULIC SYSTEM RESULTING IN SERIOUS PERSONAL INJURY. ALWAYS USE A GAUGE WHEN ADJUSTING A RELIEF VALVE.

# EXAMPLE LOADER VALVE HYDRAULIC CIRCUIT WITH OPTIONAL POWER BEYOND

