

PRINCE 'MB' MODELS (MB21BB5C1 SHOWN)

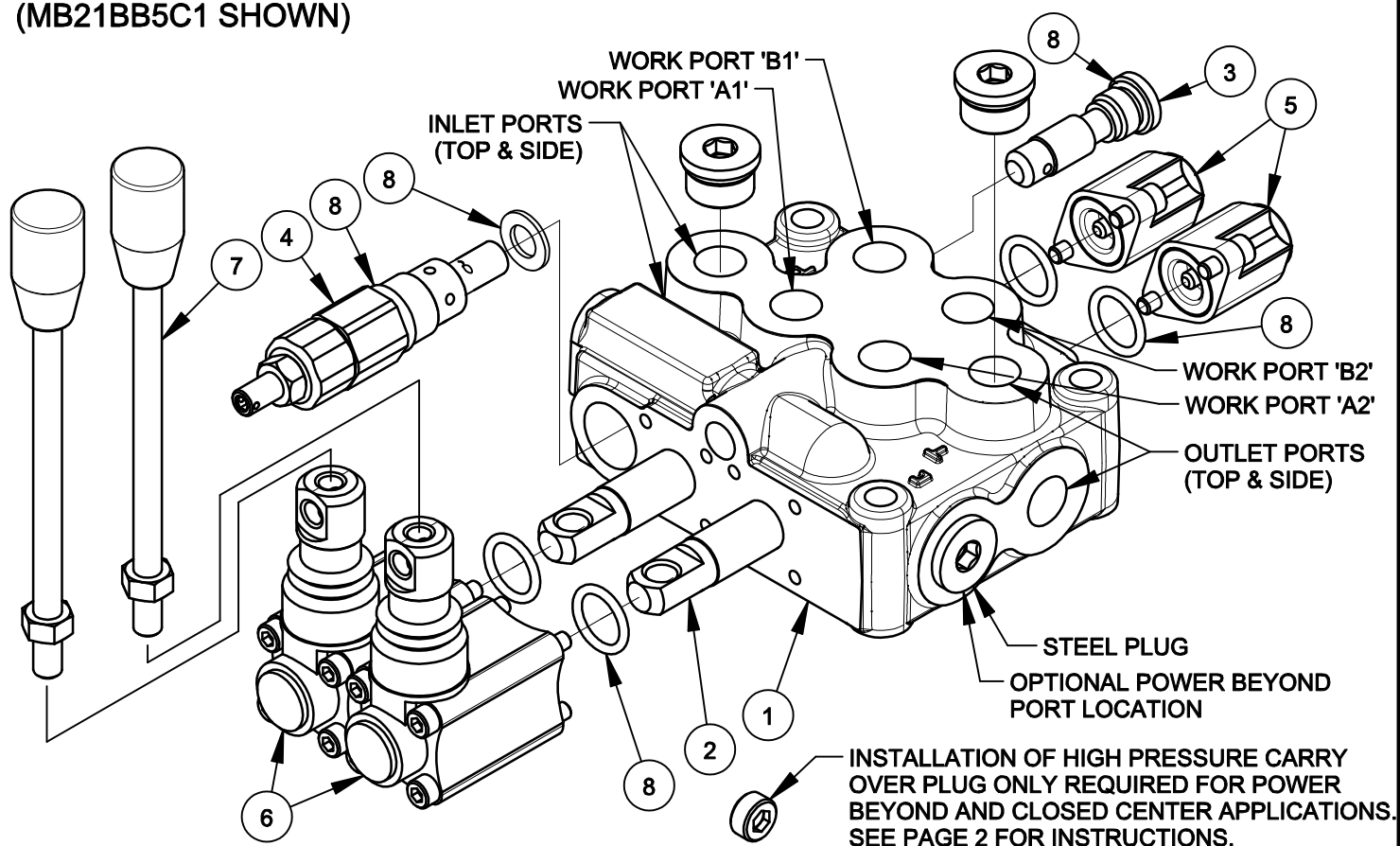

FOR STANDARD MODELS AVAILABLE
& ADDITIONAL INFORMATION GO TO:
www.princehyd.com

TORQUE NOTES:
RELIEF CARTRIDGE: 350-400 IN-LBS.
LOAD CHECK ASSY: 200-230 IN-LBS.
CAP SCREW, 5 mm (GFN): 10-12 IN-LBS.
H.P. CARRYOVER PLUG: 55-65 IN-LBS.
NOTE: CARRYOVER PLUG IS 1/4-19 BSPT AND IS NOT COMPATIBLE WITH 1/4-18 NPTF PLUGS.

PRINCE MODEL 'MB' SPECIFICATIONS:

MAXIMUM OPERATING PRESSURE: 3500 PSI
MAXIMUM TANK PRESSURE: 500 PSI
NOMINAL FLOW RATING: 8 GPM
MAX. OPERATING TEMPERATURE: 180°F
FILTRATION RECOMMENDATIONS: ISO 4406 19/17/14
STD. PORT SIZE (INLET, OUTLET, POWER BEYOND AND WORK PORTS): #8 SAE ORB, 3/4-16UNF-2B
RECOMMENDED FLUID: HIGH QUALITY MINERAL BASED HYDRAULIC FLUID WITH VISCOSITY FROM 12 cSt TO 400 cSt.

RELIEF VALVE: AN ADJUSTABLE RELIEF VALVE CARTRIDGE IS STANDARD ON ALL 'MB' MODELS. THE STANDARD FACTORY SETTING IS 2500 PSI @ 6 GPM. STANDARD ADJUSTMENT RANGE IS 2000 PSI TO 3500 PSI. THE RELIEF SETTING IS ADJUSTED BY LOOSENING THE JAM NUT, AND TURNING THE ADJUSTING SCREW. TURNING THE ADJUSTING SCREW CLOCKWISE INCREASES RELIEF PRESSURE AND COUNTERCLOCKWISE DECREASES RELIEF PRESSURE (A PRESSURE GAUGE MUST BE INSTALLED IN THE INLET LINE OR PORT WHENEVER THE RELIEF PRESSURE IS ADJUSTED).

WARNING: OVERPRESSURE MAY CAUSE SUDDEN AND UNEXPECTED FAILURE OF A COMPONENT IN THE HYDRAULIC SYSTEM RESULTING IN SERIOUS PERSONAL INJURY. ALWAYS USE A GAUGE WHEN ADJUSTING A RELIEF VALVE.

ITEM:	PART NO.:	DESCRIPTION:
1	*	VALVE BODY
2	*	SPOOL, CYLINDER
3	*	LOAD CHECK CARTRIDGE
4	660270005	RELIEF CARTRIDGE, ADJUSTABLE
5	660170057	SPRING CENTER KIT, GFN
6	660170056	HANDLE HOUSING KIT, GFN
7	660170055	HANDLE KIT
8	660570003	SEAL KIT (1 THRU 6 SPOOLS)
		* - NOT SERVICED SEPERATELY

EXAMPLE 'MB' VALVE HYDRAULIC CIRCUIT, STANDARD OPEN CENTER:

STANDARD OPEN CENTER OPERATION: DO NOT INSTALL THE HIGH PRESSURE CARRY OVER PLUG. EITHER THE TOP OR THE SIDE T PORTS OR THE C PORT MAY BE USED AS THE OUTLET. STEEL PLUGS MUST BE INSTALLED IN UNUSED PORTS.

NOTE: INTERNAL H.P. CARRY OVER PLUG IS NOT INSTALLED. EXTERNAL STEEL PORT PLUG IS REQUIRED. DISCARD H.P. CARRY OVER PLUG.

PRESSURE RELIEF VALVE NOTE: THIS RELIEF LIMITS THE MAX PUMP PRESSURE IN THE CIRCUIT.

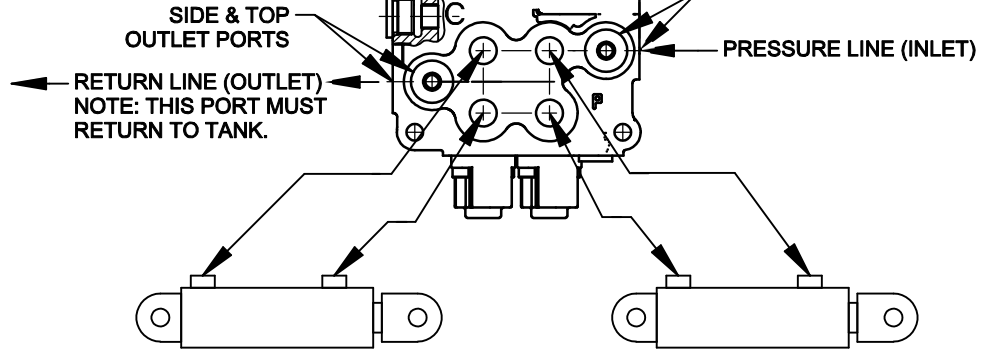

MOVING HANDLE TOWARDS VALVE DIRECTS FLOW TO THE PORT CLOSEST TO THE SPRING ATTACHMENT END OF VALVE. MOVING THE HANDLE AWAY FROM VALVE DIRECTS FLOW TO THE PORT CLOSEST TO THE HANDLE.

EXAMPLE 'MB' VALVE CIRCUIT USING OPTIONAL POWER BEYOND OPTION:

OPTIONAL POWER BEYOND OPERATION: INSTALL THE HIGH PRESSURE CARRY OVER PLUG (1/4-18 BSPT) INTO THE INTERNAL THREADS TO THE INSIDE OF THE "C" PORT. CONNECT A HYDRAULIC LINE FROM THE "C" PORT TO A DOWN STREAM FUNCTION AND THE "T" PORT TO TANK. WITH ALL SPOOLS CENTERED, OIL FLOW IS DIRECTED TO THE POWER BEYOND PORT 'C' FOR USE BY THE DOWNSTREAM FUNCTION. WHEN A SPOOL IS SHIFTED, OIL WILL BE DIRECTED TO A WORK PORT AND THE RETURN FLOW TO TANK.

NOTE: INTERNAL H.P. CARRY OVER PLUG IS NOT INSTALLED. EXTERNAL STEEL PORT PLUG IS REQUIRED. DISCARD H.P. CARRY OVER PLUG.

PRESSURE RELIEF VALVE NOTE: THIS RELIEF IS OPTIONAL. IT CANNOT BE SET HIGHER THAN THE FIRST VALVE'S RELIEF, BUT MAY BE SET LOWER.

THE INTERNAL H.P. CARRYOVER PLUG MUST BE INSTALLED IN THIS VALVE FOR POWER BEYOND OPERATION.

PRESSURE RELIEF VALVE NOTE: THIS RELIEF LIMITS THE MAX PUMP PRESSURE IN THE CIRCUIT.

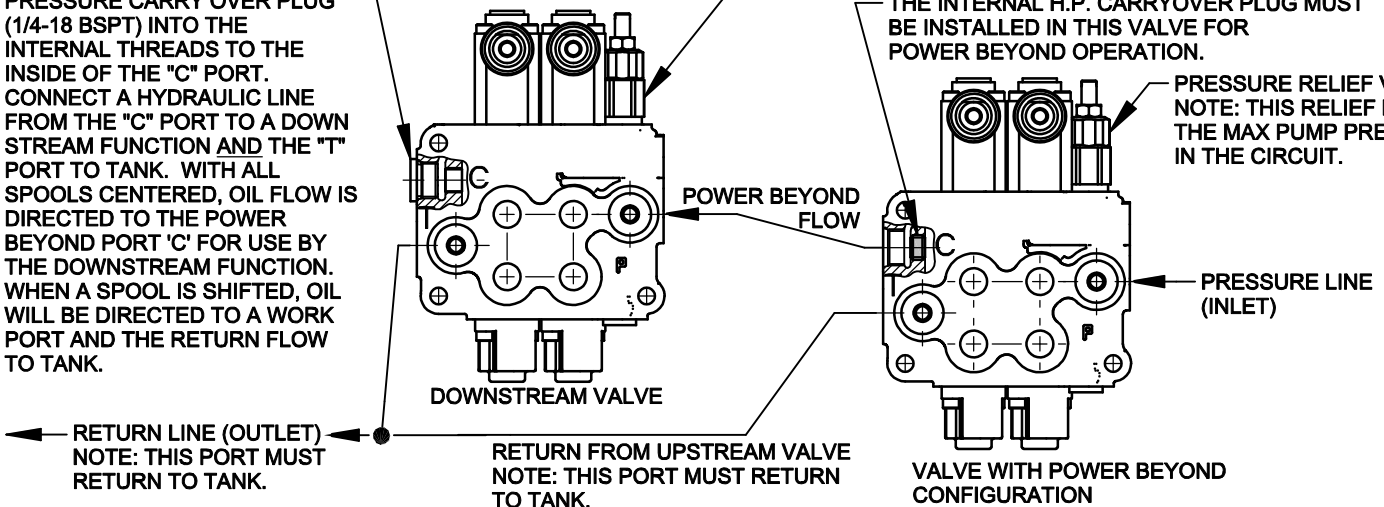

FOR STANDARD MODELS AVAILABLE & ADDITIONAL INFORMATION GO TO:
www.princehyd.com

CLOSED CENTER OPERATION: BOTH THE INTERNAL HIGH PRESSURE CARRY OVER PLUG AND A STEEL PLUG MUST BE INSTALLED IN THE C PORT. RELIEF PRESSURE MAY NEED TO BE ADJUSTED SO IT IS NOT SET LOWER THAN THE PUMP SETTING.

ADDITIONAL SERVICE PARTS

PART NO.:	DESCRIPTION:
612100001	SPOOL, MOTOR
660270006	NO-RELIEF PLUG
671900122	HIGH PRESSURE CARRY OVER PLUG (NOTE: PLUG IS 1/4-19 BSPT AND IS NOT COMPATIBLE WITH 1/4-18 NPTF PLUGS)
660170058	3 POSITION DETENT KIT
671400307	END CAP, GFN (w/ SCREWS)
671400306	END CAP, ALUMINUM (w/ SCREWS 50-60 IN-LBS)
660170060	HANDLE HOUSING KIT, ALUMINUM (w/ SCREWS 50-60 IN-LBS)
670400111	KNOB, RUBBER
660170061	JOYSTICK ASSY, COMPLETE (SEE www.princehyd.com FOR INSTALLATION DETAIL)

REF. SCHEMATIC FOR MB21BB5C1

