

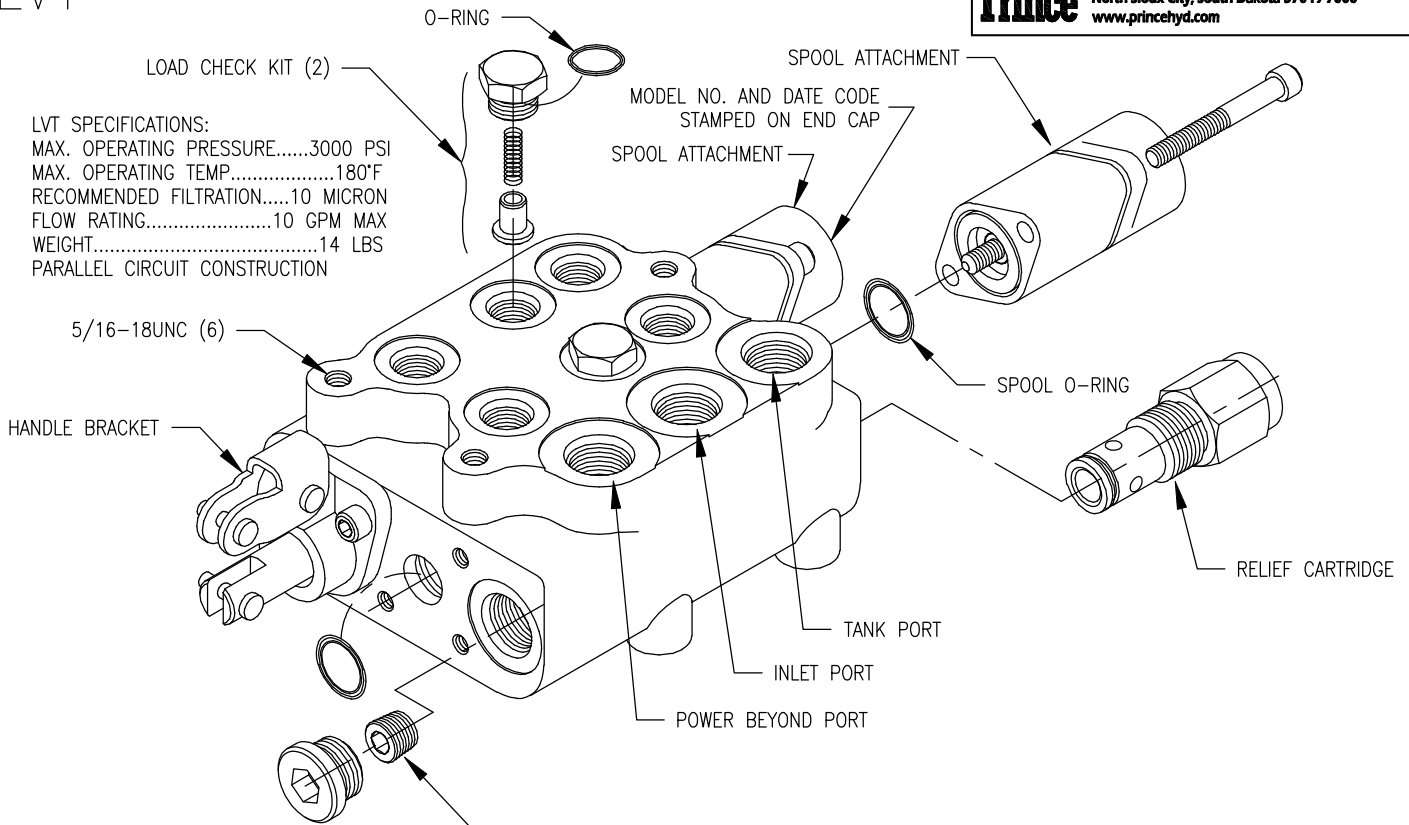

LVT



LVT SPECIFICATIONS:
 MAX. OPERATING PRESSURE.....3000 PSI
 MAX. OPERATING TEMP.....180°F
 RECOMMENDED FILTRATION.....10 MICRON
 FLOW RATING.....10 GPM MAX
 WEIGHT.....14 LBS
 PARALLEL CIRCUIT CONSTRUCTION

FOR POWER BEYOND APPLICATION, INSTALL THIS PIPE PLUG INSIDE VALVE BODY. THE POWER BEYOND PORT IS THEN CONNECTED TO THE DOWN STREAM VALVE, AND THE TANK PORT CONNECTED TO THE RESERVOIR.
 FOR OPEN CENTER APPLICATIONS DISCARD PIPE PLUG AND PUT A STEEL PLUG IN POWER BEYOND PORT.
 FOR CLOSED CENTER APPLICATIONS, INSTALL PIPE PLUG AND PUT A STEEL PLUG IN THE POWER BEYOND PORT.

NOTE:
 FEATURES MAY VARY WITH MODEL NO. CONSULT CATALOG PARTS MANUAL AVAILABLE AT www.princehyd.com

LVT KITS AND CARTRIDGES	
PART NO.	DESCRIPTION
660590017	SEAL KIT
660180076	SPRING CENTER W/FLOAT DETENT KIT
660180077	SPRING CENTER W/ REGEN KIT
660180078	SPRING CENTER KIT
660280004	NO-RELIEF PLUG (OPTION 1)
660280011	ADJUSTABLE RELIEF 500-1500 PSI (OPTION 4)
660280009	ADJUSTABLE RELIEF 1500-3000 PSI (OPTION 5)
270006122	ADJUSTABLE RELIEF 500-3000 PSI (OPTION 6)
660180073	COMPLETE LEVER HANDLE KIT
660180011	LEVER HANDLE KIT (PINS, KNOB, & HANDLE)
660180072	HANDLE BRACKET ASSEMBLY (LEVER NOT INCLUDED)
660180182	UNIVERSAL JOYSTICK SUB-ASSEMBLY KIT
660180069	JOYSTICK STRAIGHT HANDLE KIT
660180165	JOYSTICK BOOT & CABLE TIE KIT
<p>OPEN CENTER OPTION B Discard pipe plug. A steel port plug must be installed in the power beyond port.</p> <p>POWER BEYOND OPTION C Install pipe plug inside valve body. The power beyond port is connected to the downstream valve. Please note the tank port of the LVT must be connected to tank.</p> <p>CLOSED CENTER OPTION D Install pipe plug inside valve body. A steel port plug must be installed in the power beyond port. Please note the tank port of the LVT must be connected to tank.</p> <p>LOAD CHECK DESCRIPTION The load check feature is standard on all LVT series valves. Each spool has a separate load check. The load check will prevent the fall of a cylinder as the spool is shifted. The pump must build up enough pressure to overcome the pressure on the work port caused by the weight of the load before the cylinder can move. PLEASE NOTE that the load check has nothing to do with how well the valve will hold up a cylinder with that spool in neutral. The load check is functional only when the spool is shifted.</p>	<p>RELIEF OPTION 6 USES A DIFFERENT CAVITY DETAIL THAN OPTIONS 1 THRU 5 AND IS NOT INTERCHANGEABLE. TO ADJUST RELIEF CARTRIDGE, LOOSEN JAM NUT AND TURN SET SCREW CLOCKWISE TO INCREASE PRESSURE AND/OR COUNTER-CLOCKWISE TO DECREASE PRESSURE. A PRESSURE GAUGE MUST BE INSTALLED IN THE INLET LINE WHENEVER THE RELIEF PRESSURE IS ADJUSTED.</p> <p> WARNING: OVERPRESSURE MAY CAUSE SUDDEN AND UNEXPECTED FAILURE OF A COMPONENT IN THE HYDRAULIC SYSTEM RESULTING IN SERIOUS PERSONAL INJURY. ALWAYS USE A GAUGE WHEN ADJUSTING A RELIEF VALVE.</p> <p>LOADS MAY MOVE SUDDENLY WHEN VALVE SPOOLS ARE SHIFTED, EVEN WITHOUT THE PUMP RUNNING.</p>

EXAMPLE 'LVT' LOADER VALVE HYDRAULIC CIRCUIT WITH OPTIONAL POWER BEYOND

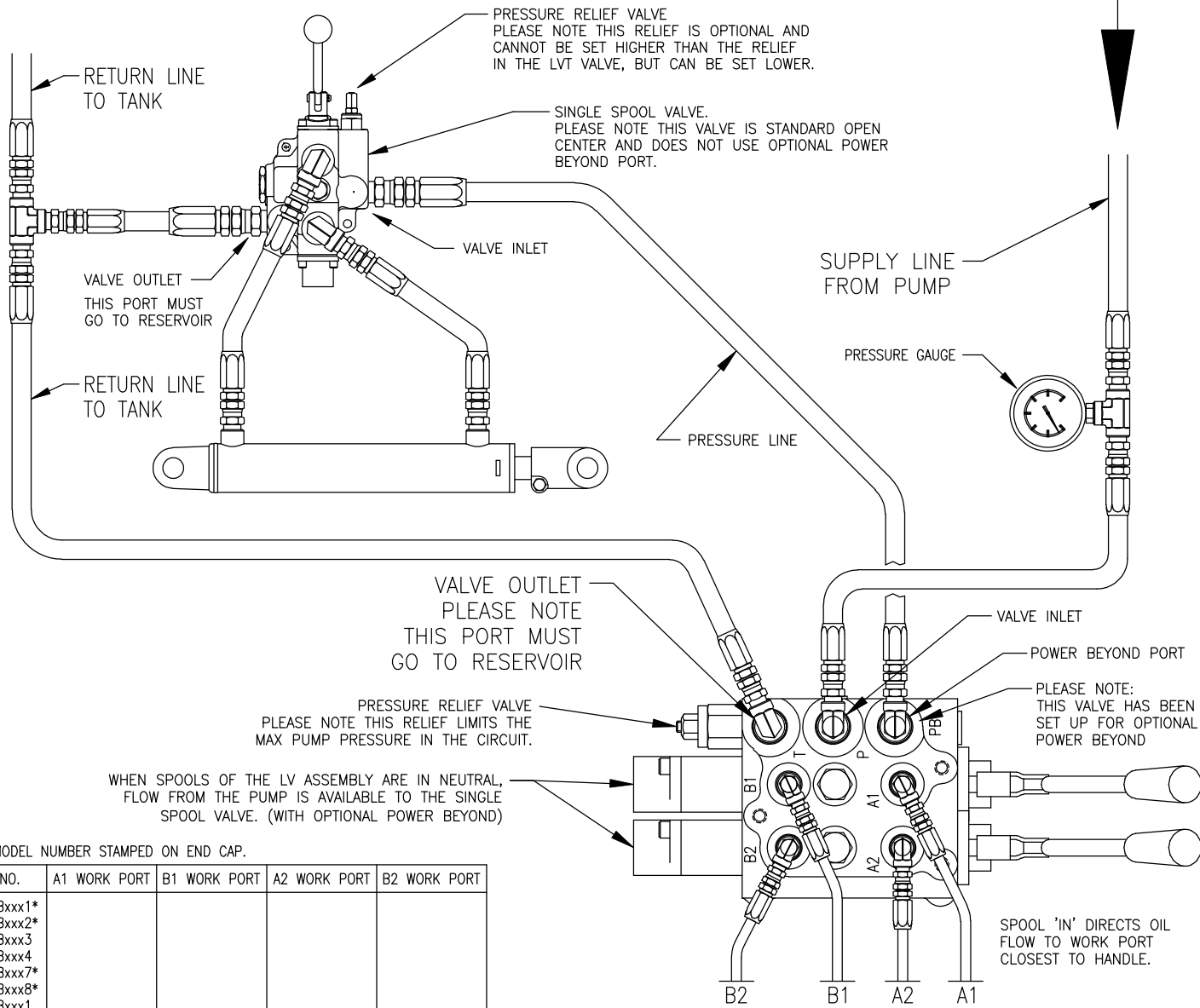

PART NO.	A1 WORK PORT	B1 WORK PORT	A2 WORK PORT	B2 WORK PORT
LVTxBBxxx1*				
LVTxBBxxx2*				
LVTxBBxxx3				
LVTxBBxxx4				
LVTxBBxxx7*				
LVTxBBxxx8*				
LVTxGBxxx1				
LVTxGBxxx2				
LVTxGBxxx3	CYL PORT 4	CYL PORT 3	CYL PORT 2	CYL PORT 1
LVTxGBxxx4				
LVTxGBxxx7*				
LVTxGBxxx8				
LVTxGRxxx1				
LVTxGRxxx2				
LVTxGRxxx3				
LVTxGRxxx4				
LVTxGRxxx7				
LVTxGRxxx8				
LVTxBBxxx5				
LVTxBBxxx6				
LVTxBGxxx1				
LVTxBGxxx2				
LVTxBGxxx5				
LVTxBGxxx6				
LVTxBGxxx7*				
LVTxBGxxx8	CYL PORT 2	CYL PORT 1	CYL PORT 4	CYL PORT 3
LVTxRGxxx1				
LVTxRGxxx2				
LVTxRGxxx5				
LVTxRGxxx6				
LVTxRGxxx7				
LVTxRGxxx8				
LVTxBGxxx3	CYL PORT 1	CYL PORT 2	CYL PORT 4	CYL PORT 3
LVTxGBxxx5	CYL PORT 4	CYL PORT 3	CYL PORT 1	CYL PORT 2

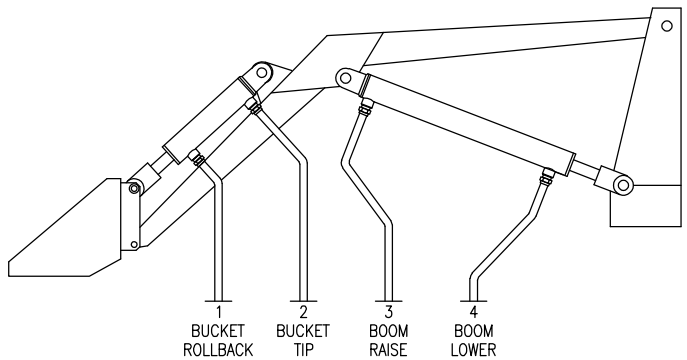

* NOTE TYPICAL WORK PORT CONNECTION; OTHER COMBINATIONS ARE POSSIBLE.