

TYPICAL SERIES 20 STACK VALVE ASSEMBLY

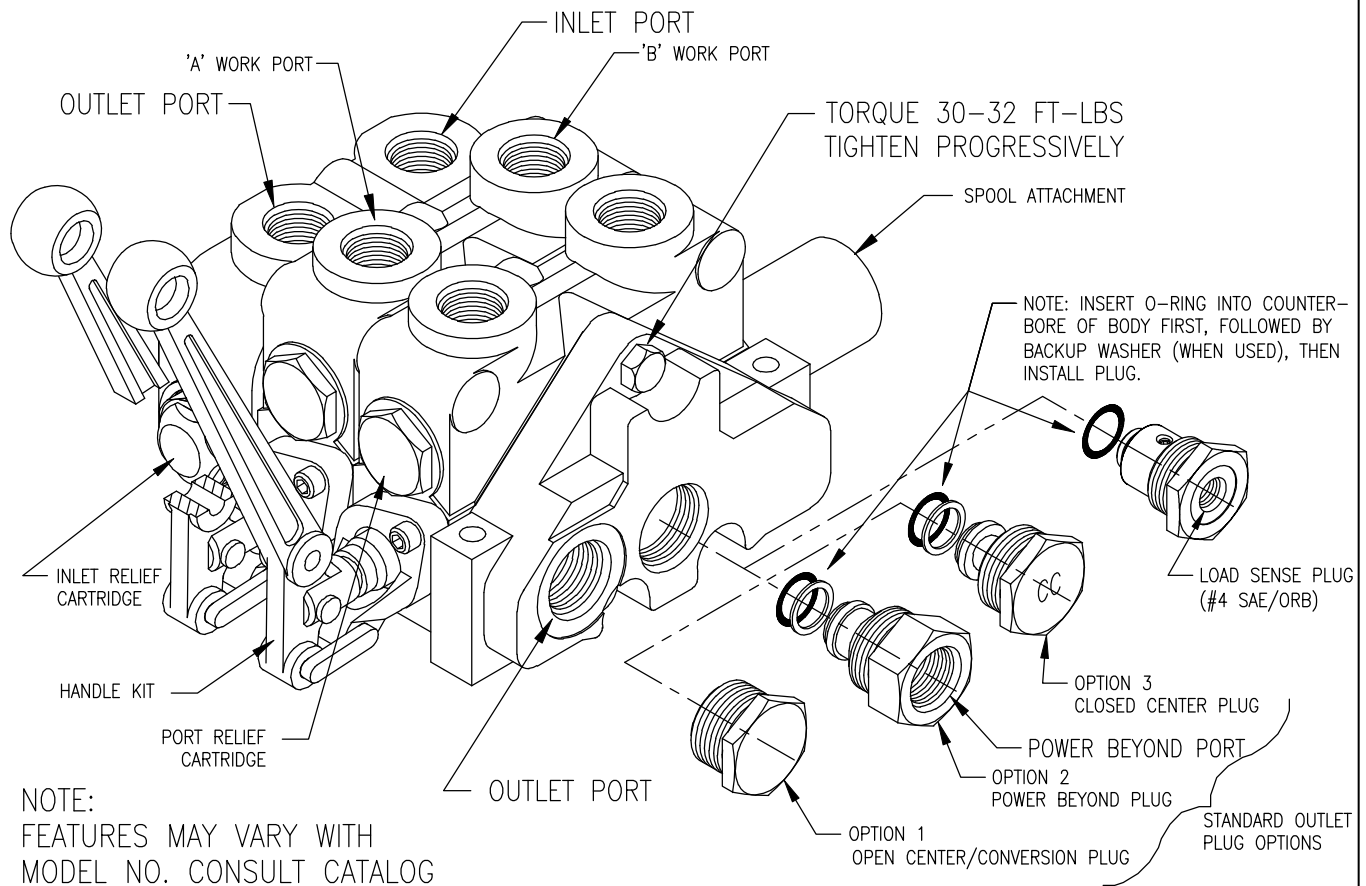

NOTE:
FEATURES MAY VARY WITH
MODEL NO. CONSULT CATALOG

STACK VALVE ASSEMBLY INSTRUCTIONS

1. INSERT TIERODS w/ONE NUT THREADED ON, OR BOLTS, THROUGH HOLES IN THE OUTLET SECTION.
2. POSITION THE OUTLET SECTION WITH TIERODS INSTALLED ON ITS SIDE SO TIERODS ARE VERTICAL. PLACE THE O-RINGS INTO GROOVES ON TOP SIDE OF OUTLET.
3. SLIDE THE WORK SECTION DOWN THE TIERODS AND POSITION OVER THE OUTLET SECTION. PLACE THE O-RINGS INTO GROOVES ON TOP SIDE OF WORK SECTION.
4. REPEAT FOR REMAINING WORK SECTIONS AND INLET. MAKE CERTAIN O-RINGS STAY IN GROOVES DURING ASSEMBLY.
5. INSTALL REMAINING NUTS. PROGRESSIVELY TIGHTEN TIERODS TO 30-32 FT-LBS. ENSURE TIERODS EXTEND THROUGH ALL HEX NUTS.
6. INSTALL HANDLES AND OPERATE SPOOLS. MAKE CERTAIN THAT SPOOLS DO NOT BIND AND THAT SPOOLS WITH SPRING CENTER RETURN TO NEUTRAL.
7. IF A SPOOL BINDS LOOSEN TIEROD NUTS. RE-TORQUE ALL NUTS TO 20, THEN 25, AND FINALLY 30 FT-LBS.
8. IF A SPOOL STILL BINDS CHECK FOR A SMASHED O-RING OR CONTAMINATION BETWEEN THE SECTIONS.
9. EXTRA O-RINGS ARE PROVIDED WITH KIT.

PLEASE NOTE:

BE VERY CAREFUL NOT TO NICK OR SCRATCH THE PRECISION GROUND SURFACES OF THE SECTIONS. ALSO TAKE CARE TO KEEP THESE SURFACES CLEAN DURING ASSEMBLY.

POWER BEYOND PLUG WITH #10 SAE ORB PORT OPTION 2 (*):

This option provides for a high pressure power beyond port. This would be used if a valve is to be added downstream.
PLEASE NOTE: The outlet must be connected to tank. When spools are in neutral the inlet is connected to power beyond port.

* A power beyond plug with 3/4-NPTF is also available, see page 2.

CLOSED CENTER PLUG OPTION 3:

This option provides for closed center operation. This is typically used with a variable displacement pressure compensated pump or in a system with an unloading valve. When the spools are in neutral the inlet port is blocked. The power beyond plugs can be used for closed center conversion by plugging the power beyond port. PLEASE NOTE: It may be necessary to increase relief pressure above pump compensator setting.

LOAD SENSE PLUG:

This plug is installed in a load sense outlet (20LExx) and provides a load sense port and an optional load sense bleed-down. Load sense systems typically have a variable displacement pump with pressure and flow compensation that requires feedback from a load sense valve in the form of a pressure signal. The load sense port on the load sense plug provides the pressure signal required by the pump control. An optional orifice in the load sense plug bleeds the pressure signal when pressure bleed-off is not provided by the pump. The load sense outlet is used with load sense work sections.

3 WAY SPOOLS OPTION 'A':

The 'A work port' is plugged. Connect 'B work port' to cylinder.

LOAD CHECK:

The load check feature is standard on all 20 series valves. Each spool has a separate load check. The load check will prevent the fall of a cylinder as the spool is shifted. It also prevents the backflow of oil from the work port to the inlet. The pump must build up enough pressure to overcome the pressure on the work port caused by the weight of the load before the cylinder can move. PLEASE NOTE: The load check has nothing to do with how well the valve will hold up a cylinder with the spool in neutral. The load check is functional only while the spool is being shifted.

EXAMPLE SERIES 20 STACK VALVE OPEN
CENTER HYDRAULIC CIRCUIT WITH OPTIONAL
POWER BEYOND

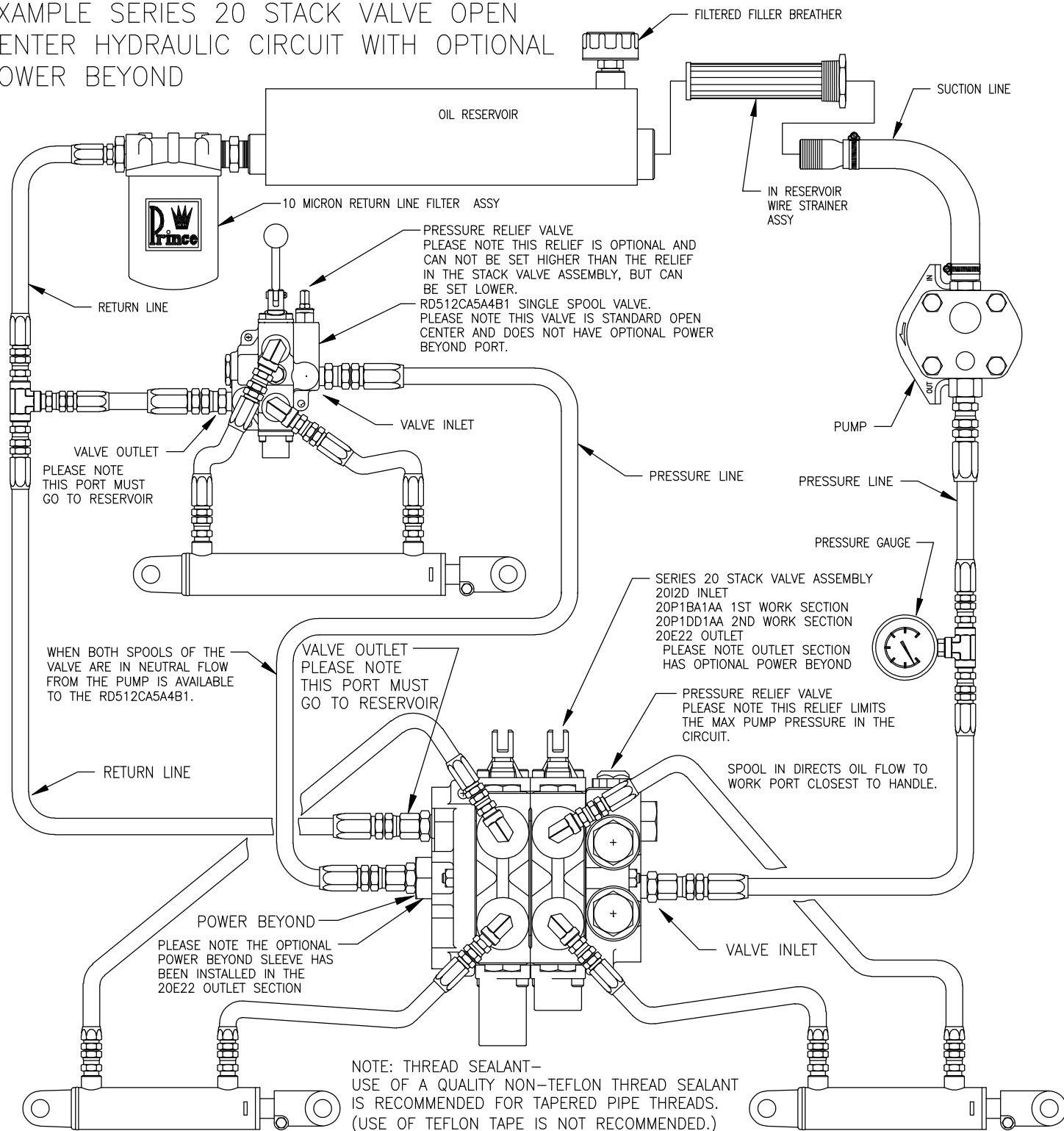

SERIES 20 KITS AND CARTRIDGES:

PART NO.	DESCRIPTION	PART NO.	DESCRIPTION
660585001	20P/20T SEAL KIT	660290002	PORT RELIEF (OPTION A) NO-RELIEF PLUG
660585008	20L SEAL KIT	660290101	PORT RELIEF (OPTION F) ADJ. RELIEF CART 500-1350 PSI
660585005	FLOAT SECTION SEAL KIT	660290103	PORT RELIEF (OPTION G) ADJ. RELIEF CART 1351-1750 PSI
660585004	BETWEEN SECTION SEAL KIT	660290105	PORT RELIEF (OPTION H) ADJ. RELIEF CART 1751-2200 PSI
660290007	CHECK VALVE CARTRIDGE (LOCK SECTION)	660290107	PORT RELIEF (OPTION J) ADJ. RELIEF CART 2200-3000 PSI
660190003	SPRING CENTER KIT	660290001	INLET RELIEF (OPTION A) NO-RELIEF PLUG
660190004	3 POSITION DETENT KIT	660290201	INLET RELIEF (OPTION F) ADJ. RELIEF CART 500-1350 PSI
660190005	FRICITION DETENT KIT	660290203	INLET RELIEF (OPTION G) ADJ. RELIEF CART 1351-1750 PSI
660190011	PIN KIT	660290205	INLET RELIEF (OPTION H) ADJ. RELIEF CART 1751-2200 PSI
660190007	COMPLETE HANDLE KIT, STANDARD	660290207	INLET RELIEF (OPTION J) ADJ. RELIEF CART 2200-3000 PSI
660190002	HANDLE KIT, STANDARD (HANDLE, KNOB, PINS)	660290006	OPEN CENTER CONVERSION PLUG (OPTION 1)
660190006	COMPLETE HANDLE KIT, VERTICAL	660290004	POWER BEYOND PLUG, #10 SAE PORT (OPTION 2)
660190001	HANDLE KIT, VERTICAL (HANDLE, KNOB, PINS)	660290005	CLOSED CENTER PLUG (OPTION 3)
		660290017	POWER BEYOND PLUG, 3/4-NPTF PORT

STANDARD RELIEF SETTINGS:
 OPTION F 1350 PSI
 OPTION G 1750 PSI
 OPTION H 2200 PSI
 OPTION J 2500 PSI