

MODEL RD-1900

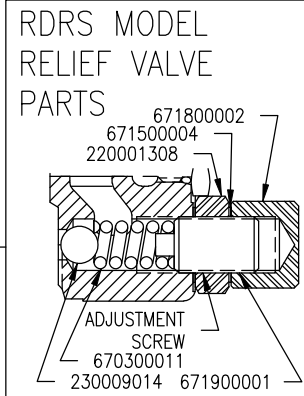

MODEL RD-100

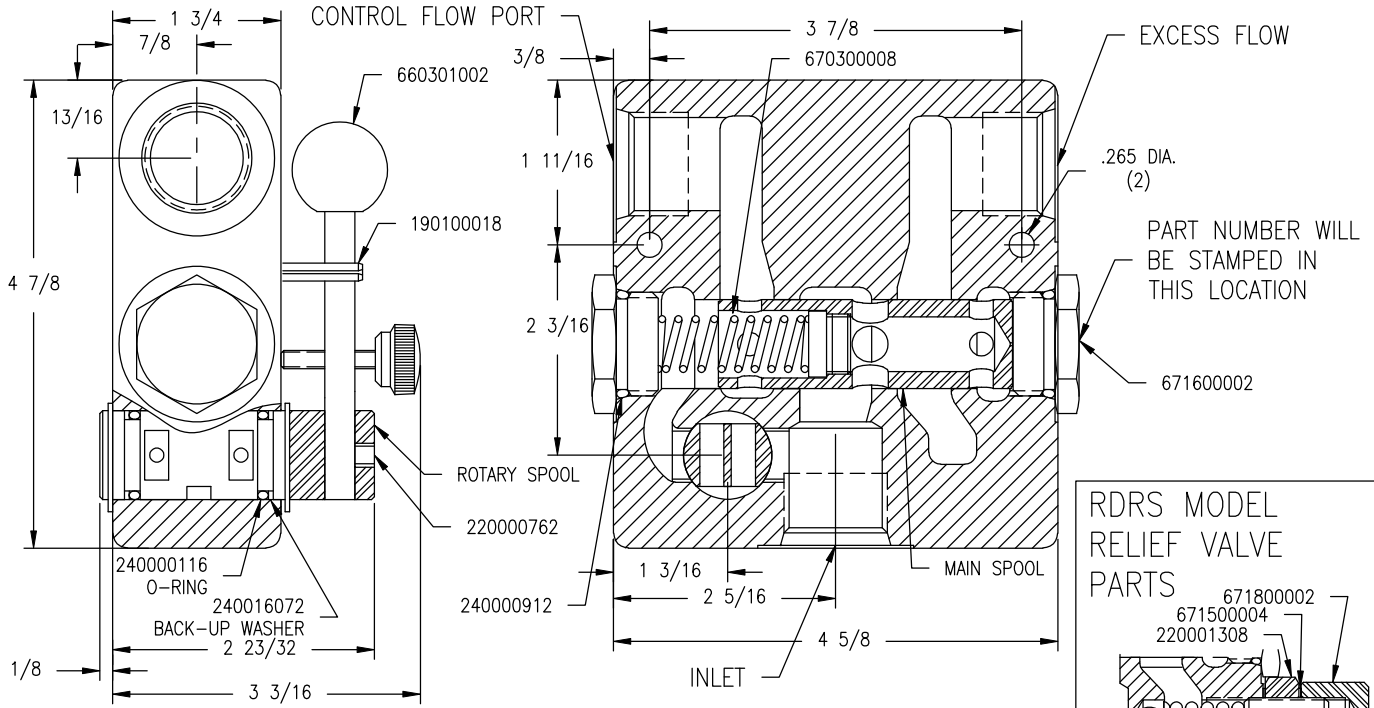
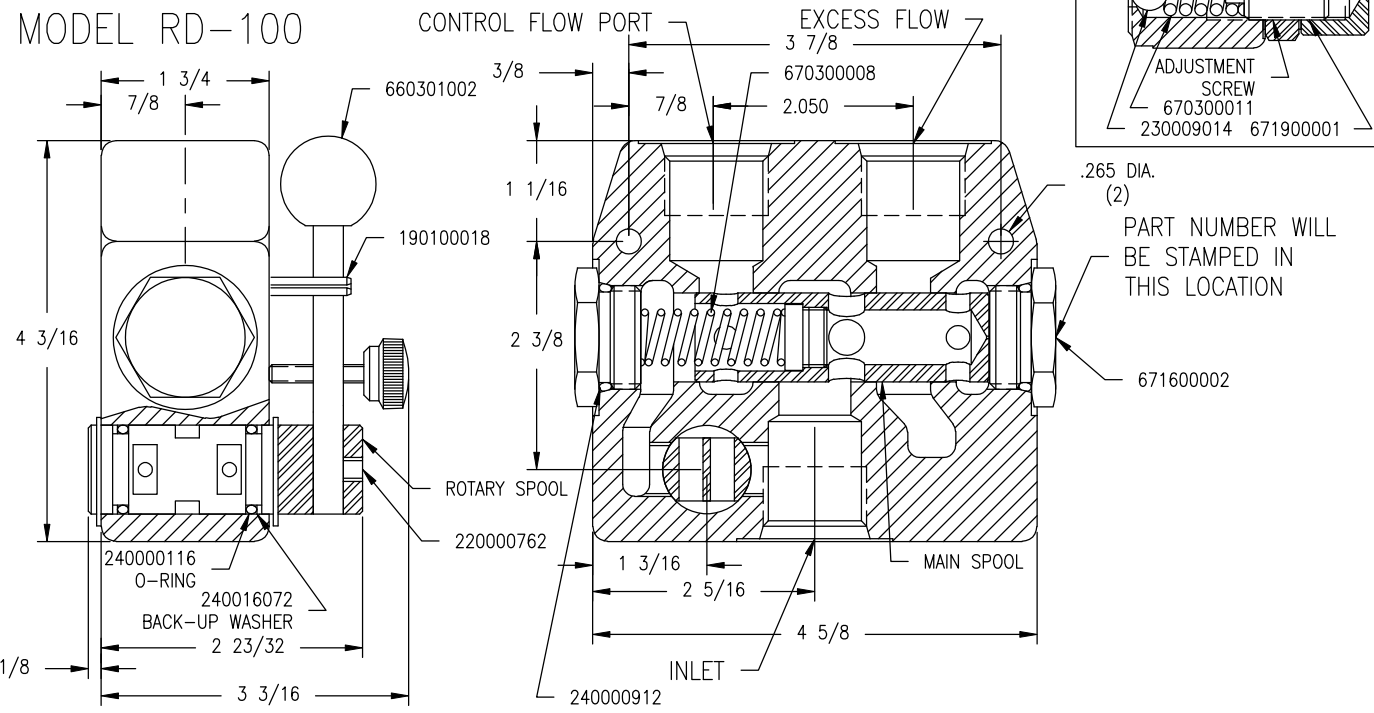

RD-100 & RD-1900

SPOOL SEAL INSTALLATION PROCEDURE:
 INSTALL ONE O-RING AND BACKUP WASHER IN THE GROOVE ON HANDLE END OF ROTARY SPOOL. PUSH SPOOL THRU FROM HANDLE SIDE JUST FAR ENOUGH TO EXPOSE O-RING GROOVE ON THE BACKSIDE. INSTALL THE OTHER O-RING AND BACK-UP WASHER AND PUSH SPOOL BACK. LUBRICATE SEALS BEFORE INSTALLATION.

RELIEF PRESSURE ADJUSTMENT PROCEDURE:
 REMOVE ACORN NUT, LOOSEN JAM NUT AND TURN ADJUSTING SCREW CLOCKWISE TO INCREASE PRESSURE AND COUNTERCLOCKWISE TO DECREASE PRESSURE. RELIEF ADJUSTABLE FROM 1000 PSI TO 2500 PSI.

MODEL RD-100/1900 KITS

PART NO.	DESCRIPTION
660501001	SEAL KIT
660301002	HANDLE HARDWARE KIT



WARNING: OVERPRESSURE MAY CAUSE SUDDEN AND UNEXPECTED FAILURE OF A COMPONENT IN THE HYDRAULIC SYSTEM RESULTING IN SERIOUS PERSONAL INJURY. ALWAYS USE A GAUGE WHEN ADJUSTING A RELIEF VALVE.

EXAMPLE CIRCUITS RD-100/RD-1900

BYPASS CIRCUIT

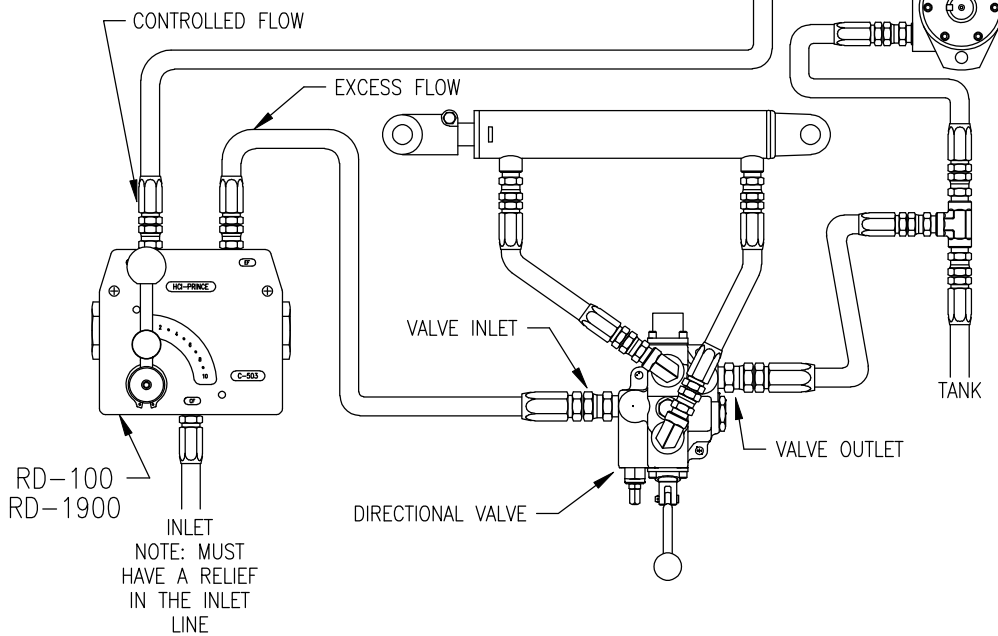

In this circuit oil from a source is directed into the inlet of the valve. By moving the handle the flow can be varied from zero when handle is vertical to maximum when handle is horizontal. Oil not going to the controlled flow port is bypassed to the excess flow port where it can be used to supply another circuit or returned to tank. It should be noted that whenever these or any valve is used to bypass or restrict flow heat will be generated.

RESTRICTIVE CIRCUIT NORMALLY USED IN CLOSED CENTER SYSTEM OR A SYSTEM WITH PRESSURE COMPENSATED PUMP

The RD-100/RD-1900 can be used as a restrictive type flow control. In this circuit the excess flow port is blocked. This would normally be used with a pressure compensated pump or in a closed center system. It should be noted that whenever these or any valve is used to bypass or restrict flow heat will be generated.

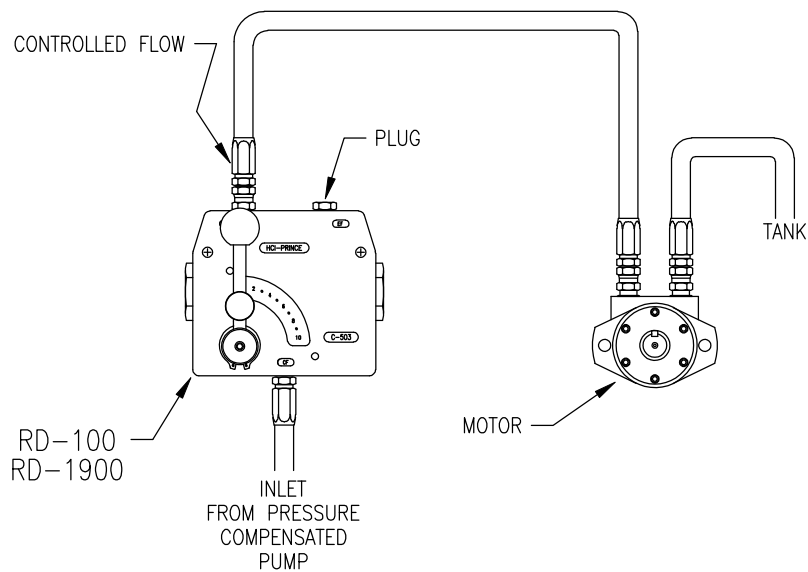

RDRS-100 CIRCUIT

RDRS Models have a built in relief valve that bypasses oil from inlet to the excess flow port when the relief setting is reached. The factory setting is 1500 psi @ 12 gpm. The excess flow port must be connected to tank.

ALL MODELS:
NOTE: THREAD SEALANT—
USE OF A QUALITY NON-TEFLON THREAD SEALANT IS RECOMMENDED FOR TAPERED PIPE THREADS.
(USE OF TEFLON TAPE IS NOT RECOMMENDED.)

