

RD-2500 TYPICAL

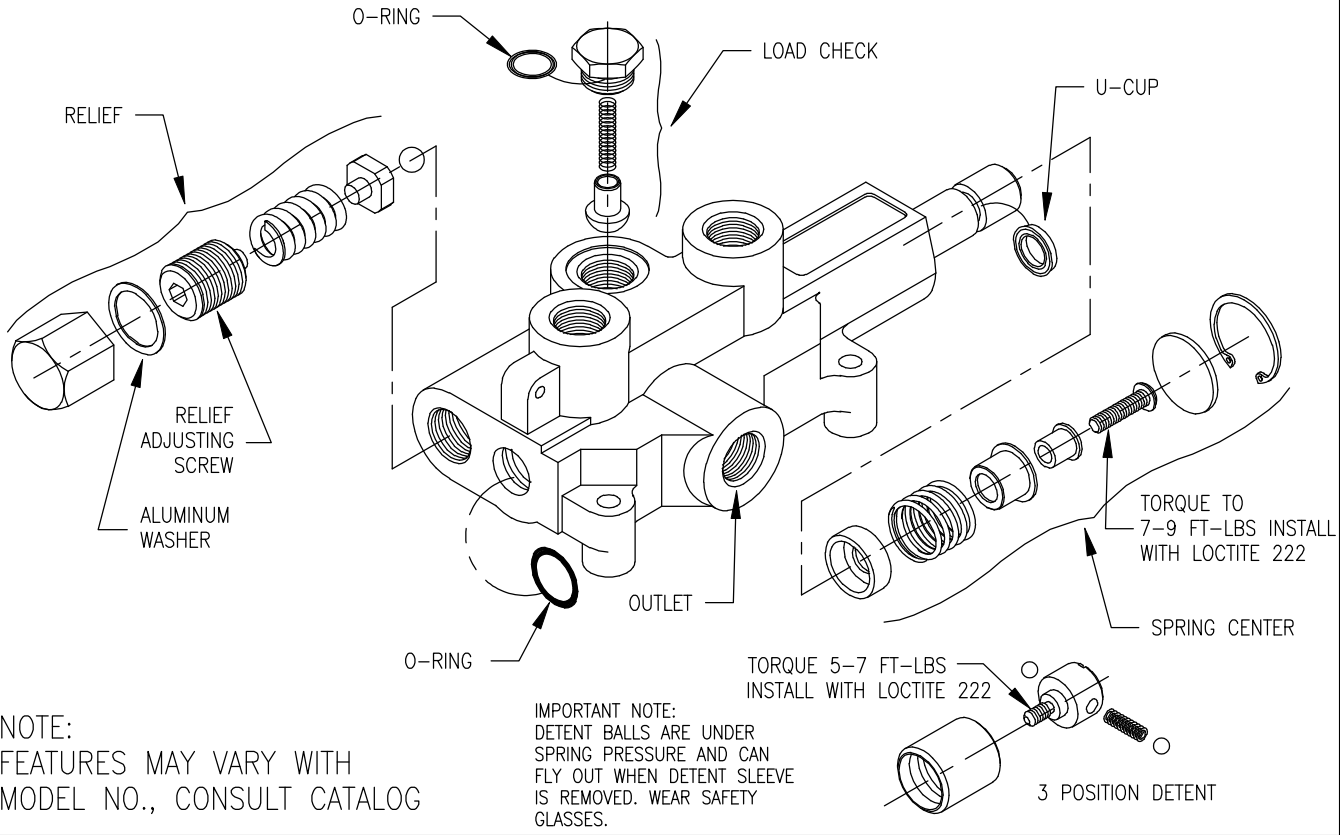

RELIEF VALVE:

An adjustable ball spring relief valve is standard on all RD-2500 valves. The standard factory setting is 1500 psi @ 12 gpm and 120°F. Other settings can be specified. The relief pressure is adjusted by removing acorn nut, and turning the adjusting screw. Turning the adjusting screw clockwise will increase the pressure and counterclockwise will decrease the pressure (a pressure gauge must be installed in the inlet line whenever the relief pressure is adjusted). Do not back out adjusting screw to the point it falls out.



WARNING: OVERPRESSURE MAY CAUSE SUDDEN AND UNEXPECTED FAILURE OF A COMPONENT IN THE HYDRAULIC SYSTEM RESULTING IN SERIOUS PERSONAL INJURY. ALWAYS USE A GAUGE WHEN ADJUSTING A RELIEF VALVE.

LOAD CHECK:

The load check feature is standard on most RD-2500 series valves. The load check will prevent the fall of a cylinder as the spool is shifted. It also prevents the backflow of oil from the work port to the inlet. The pump must build up enough pressure to overcome the pressure on the work port caused by the weight of the load before the cylinder can move.

PLEASE NOTE: The load check has nothing to do with how well the valve will hold up a cylinder with the spool in neutral. The load check is functional only when the spool is shifted.

OPEN CENTER TO CLOSED CENTER CONVERSION RD-2575 MODELS ONLY

THIS FEATURE ALLOWS AN OTHERWISE OPEN CENTER VALVE TO BE CONVERTED TO CLOSED CENTER OPERATION. AS SHOWN AT RIGHT, A 3/8-NPTF PIPE PLUG IS INSTALLED IN THE BOTTOM OF THE OUTLET PORT TO BLOCK OPEN CENTER PASSAGE. A PIPE THREAD SEALANT SHOULD BE USED. THIS FEATURE IS STANDARD ON ALL VALVES WITH 3/4-NPTF INLET AND OUTLET PORTS. THE PIPE PLUG IS INCLUDED WITH THESE MODELS. DISCARD THE PIPE PLUG IF THE VALVE IS USED ON AN OPEN CENTER APPLICATION. PLEASE NOTE, IT MAY BE NECESSARY TO ADJUST RELIEF VALVE PRESSURE WHEN A PRESSURE COMPENSATED PUMP IS USED.

RD-2500 KITS AND CARTRIDGES

PART NO.	DESCRIPTION
660525001	RD-2500 SEAL KIT
660125001	3 POSITION DETENT KIT
660125004	RELIEF KIT
660150015	LOAD CHECK KIT
660125002	SPRING CENTER KIT
660130001	COMPLETE HANDLE KIT

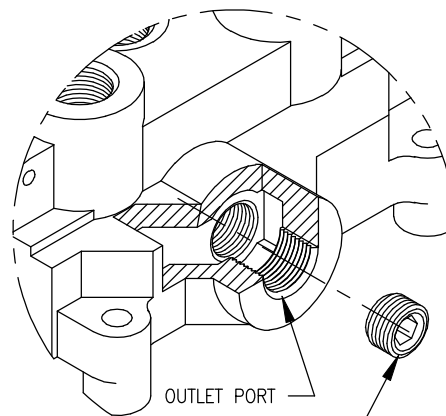

3/8-NPTF PIPE PLUG
PART NO. 200018002

EXAMPLE RD-2500 HYDRAULIC CIRCUIT

NOTE: THREAD SEALANT—
USE OF A QUALITY NON-TEFLON THREAD
SEALANT IS RECOMMENDED FOR TAPERED
PIPE THREADS. (USE OF TEFLON TAPE IS
NOT RECOMMENDED.)

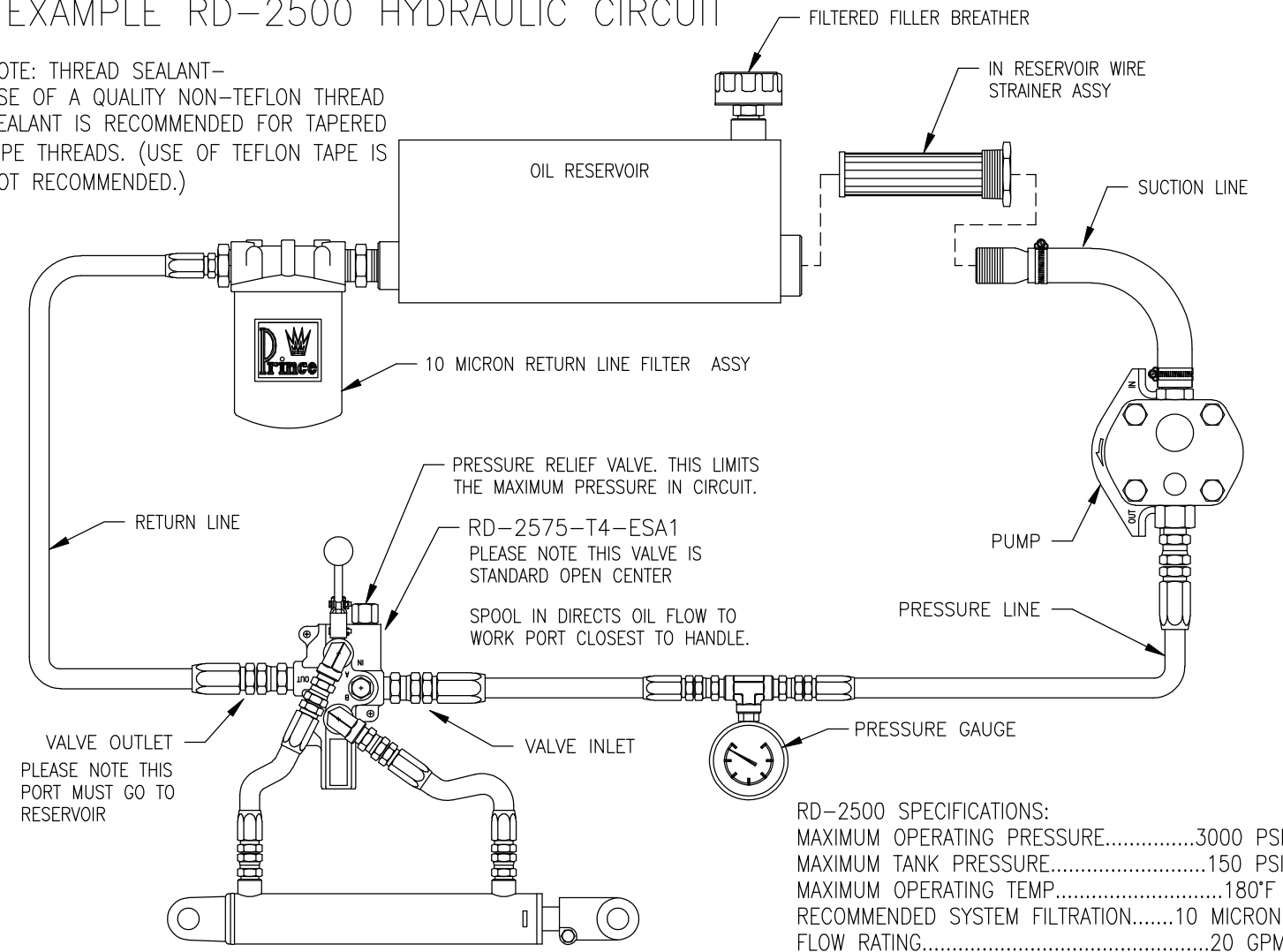

RD-2500 SPECIFICATIONS:
 MAXIMUM OPERATING PRESSURE.....3000 PSI
 MAXIMUM TANK PRESSURE.....150 PSI
 MAXIMUM OPERATING TEMP.....180°F
 RECOMMENDED SYSTEM FILTRATION.....10 MICRON
 FLOW RATING.....20 GPM

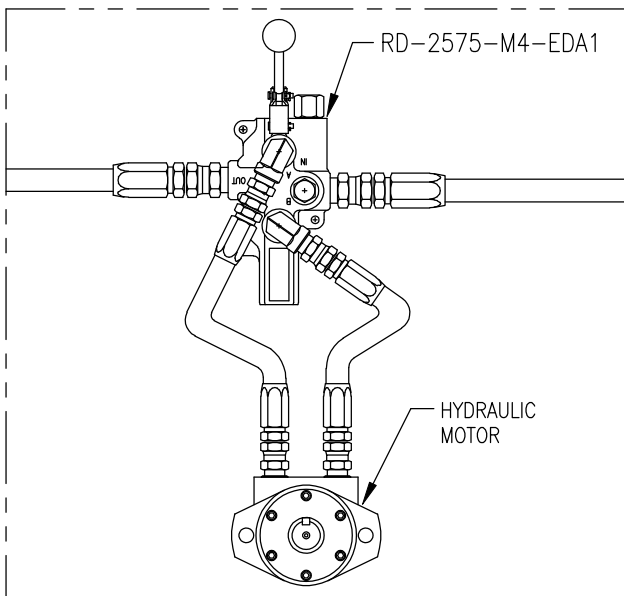

EXAMPLE MOTOR SPOOL CIRCUIT,
SPOOL OPTION M4, WHEN THE SPOOL
IS IN NEUTRAL MOTOR WILL FREE
WHEEL TO A STOP.

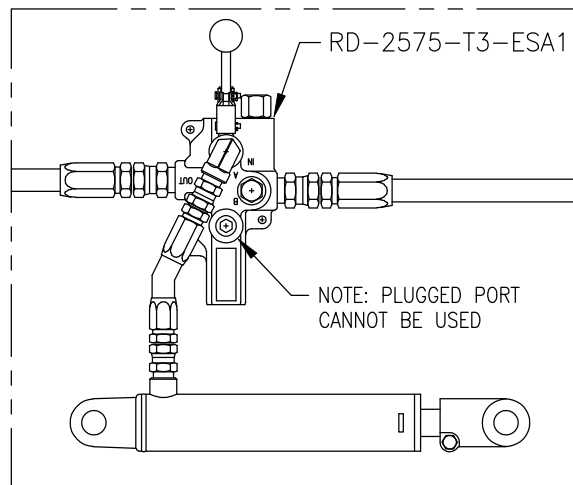

EXAMPLE 3 WAY SPOOL CIRCUIT,
SPOOL OPTION T3.

INSTALL HANDLE AS SHOWN

