

SPD2 DOUBLE PUMPS

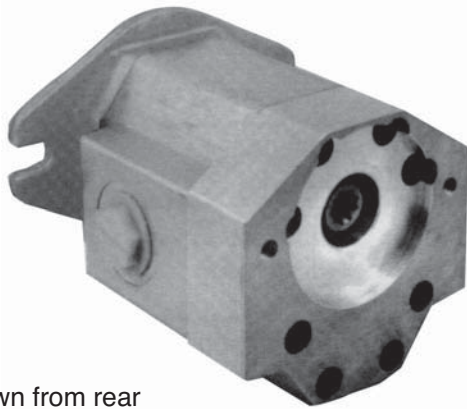

The SPD2 series of pumps are special SP-25A series pumps with through shafts. The through shafts have 9 tooth internal splines at the rear and the pump's rear cover has an integral SAE A-2 bolt mount pad. For double pump operation, a standard SAE A-2 bolt-splined shaft pump can be directly mounted on the rear on the SPD2. Typical performance of the pump is the same as indicated for the SP-25A series pump.

SPD2 as shown from rear

MODEL NO. CODING

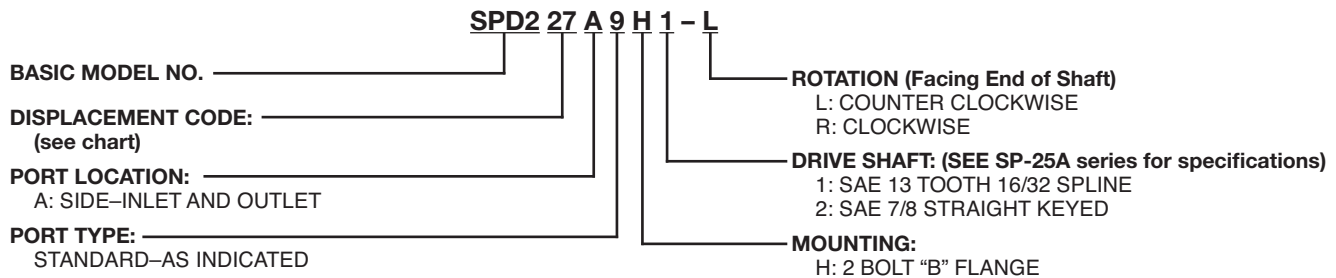

SPECIFICATIONS

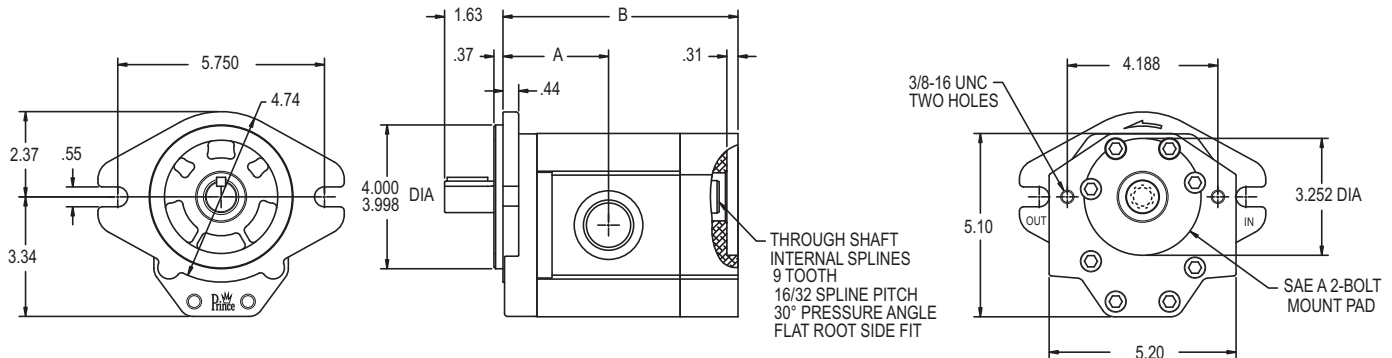

SPD2 THROUGH SHAFT PUMPS (PLUG-IN STYLE DOUBLE PUMPS)

MODEL NUMBER & DISPLACEMENT CODE	DISP. IN ³ /REV	RATED* PRESSURE (PSI)	MAX RPM	A (IN)	B (IN)	INLET PORT SIZE [°]	OUTLET PORT SIZE [°]	WT. (LB.)
SPD219	1.141	3000	3000	2.49	5.65	1 5/16-12	1 1/16-12	12.9
SPD222	1.349	3000	3000	2.55	5.77	1 5/16-12	1 1/16-12	13.1
SPD227	1.660	3000	3000	2.64	5.95	1 5/16-12	1 1/16-12	13.5
SPD232	2.008	3000	3000	2.74	6.15	1 5/8-12	1 5/16-12	13.9
SPD238	2.318	3000	3000	2.83	6.32	1 5/8-12	1 5/16-12	14.4
SPD244	2.697	3000	3000	2.94	6.54	1 5/8-12	1 5/16-12	14.9
SPD252	3.179	2500	3000	3.07	6.81	1 5/8-12	1 5/16-12	15.7
SPD263	3.869	2500	3000	3.27	7.21	1 7/8-12	1 5/16-12	16.4

[°] Standard ports as indicated are UN-2B straight thread O-Ring boss ports. Optional sizes and configurations are available. Consult factory. *Maximum operating pressure may be decreased depending on the displacement and operating pressure of the rear pump. The combination must conform to the following equation $PF \times DF + PR \times DR < 13200$ where PF and PR are the operation pressures (psi) and DF and DR are the displacements (in³/rev) for the front and rear pumps respectively.