

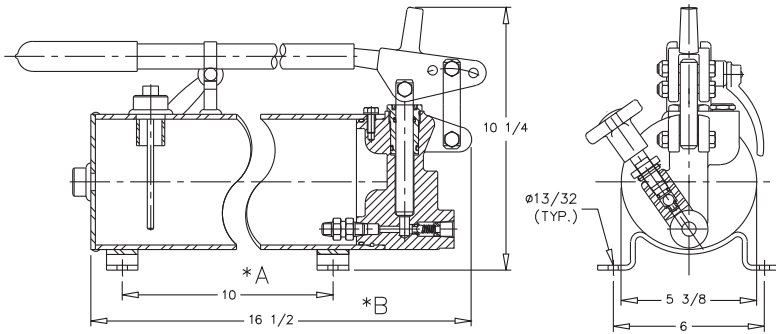

PRINCE HAND PUMP



MODEL	WT.	RESERVOIR SIZE
PM-HP-30B	55 lbs.	3 Gallons
PM-HP-20B	42 lbs.	2 Gallons
PM-HP-15B	35 lbs.	1 1/2 Gallon
PM-HP-10B	30 lbs.	1 Gallon
PM-HP-5B	27 lbs.	1/2 Gallon

Used for 1000-3000 PSI

	A	B
PM-HP-30B	36 1/4	42 5/16
PM-HP-20B	23 1/8	29 3/16
PM-HP-15B	16 9/16	22 5/8
PM-HP-10B	10	16 1/2
PM-HP-5B	3 7/16	9 15/16

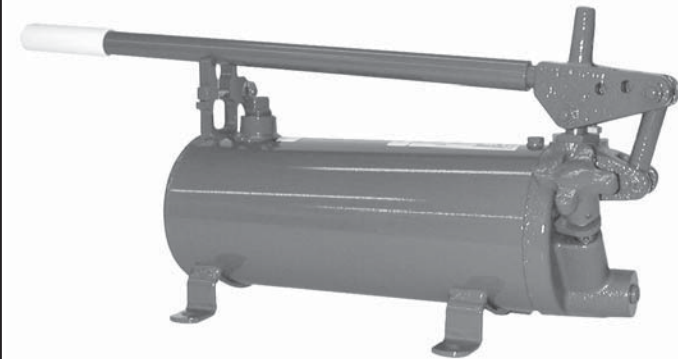

FEATURES

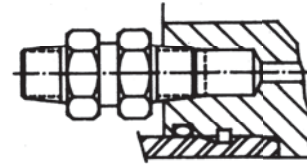

REPLACEABLE INLET CHECK VALVE

Zero leakage check valve assembly can be easily replaced when necessary.

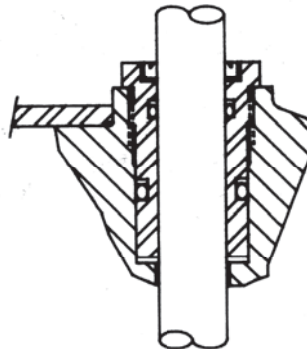

REMOVABLE PACKING GLAND

Packing gland seals can be easily replaced when necessary. Gland is removable with standard tools. New seals are readily available.

FEATURES

The Prince Hand Pump offers definite advantages over similar components of higher cost. The pump has unique design features which insure versatility. The handle can be used in (2) positions. The pump can be mounted vertically and horizontally. There are (3) different volume and pressure settings.

Position 1: 1.25 cu. in. per stroke—1500 psi*

Position 2: .95 cu. in. per stroke—2000 psi*

Position 3: .60 cu. in. per stroke—3000 psi*

*At applied force of 60-65 lbs. on handle. (Pressure to 6,000 psi can be developed with more force)

APPLICATIONS

This hand pump is designed for use wherever hydraulic pressure is needed without large flow requirements. Its sturdy design and positive sealing features will provide excellent service with a minimum of care. Uses range from mobile equipment to shop presses. Recommended temperatures may range from -40°F to 300°F. Most general purpose hydraulic oils can be used.

HYDRAULIC CYLINDER APPLICATIONS

This pump is designed for use with single acting cylinders. It may be used with double acting cylinders provided a two-way hand valve is used to direct the flow and a return port is installed on the reservoir.

SPECIFICATIONS

PISTON 11/16" dia. Chromed & Ground Steel
 PRESSURE SEALS ... O-ring & Hytrel Back-up Washers
 HANDLE Extra—heavy Pipe, 14 3/4" long
 HANDLE POSITION..... Selective — two-position
 PORT SIZE..... 3/8 NPTF
 RESERVOIR Steel Tubing
 MOUNTING FIXTURES 4-Bolt Foot Mount for 3/8 Bolts
 MOUNTING Horizontal or vertical
 FLOAT CHECK..... Prevent oil from sloshing out
 DIPSTICK To check oil level
 HANDLE CARRIER..... To prevent losing handle